

INSTRUCTIONS

VARIABLE THRESHOLD NEUTRAL ISOLATOR



DAIRYLAND
ELECTRICAL INDUSTRIES

ALWAYS RUGGED. ALWAYS RELIABLE.



INTRODUCTION

The VTNI is designed specifically for installation between the primary neutral of a power utility distribution system and the secondary neutral of a customer service. It performs two basic functions: (1) it reduces the neutral-to-earth voltage on the secondary neutral caused by the normal neutral-to-earth voltage on the primary neutral and (2) it maintains the safety aspects of solidly connected primary and secondary neutrals by reconnecting these neutrals any time the voltage difference between neutrals exceeds a predetermined voltage threshold level.

WARNING

The Dairyland model VTNI is not authorized for use in solving nuisance shock to persons at swimming pools or similar human health situations where structure to ground voltage is present. Instead, proper bonding and grounding techniques need to be applied to solve such problems.

Product Rating

The 60 Hz short-duration (i.e. fault current rating) is included in the Ratings Table. This product is to be applied where the available fault current/time duration from the power utility system (primary system) is less than or equal to the values given in the table of ratings. Where fault current on a utility system at the point of installation exceeds the VTNI rating, a current limiting fuse may need to be installed.

Ratings for VTNI-170-45		
60 Hz AC-RMS Rating		
Amperes	Cycles	i ² t Rating
3200	1	170 x 10 ³
2400	3	288 x 10 ³
1900	10	602 x 10 ³
1700	30	1445 x 10 ³
Lightning Surge Current (8 x 20 microsecond waveform)		
30,000 Amperes crest		
60 Hz Voltage Rating		
For use on 15kV, 25kV or 35kV Class Distribution Systems		
Switching Threshold Voltage		
Reference Figures 2 & 3 of VTNI Technical Literature		
Operating Temperature		
-40°F to +140°F (-40°C to +60°C)		

PRODUCT INSTALLATION

Pole-Type Transformer Installation

- 1) Install the isolator on the pole near the transformer with the lag bolts provided. The isolator must be positioned so that the clearances required by code are maintained between all neutral conductors and any communication conductors.
- 2) The primary neutral and transformer tank should be connected to one terminal of the isolator and to a primary neutral grounding electrode. The secondary neutral should be connected to the other terminal and to a separate secondary neutral grounding electrode. To obtain isolation between the primary and secondary neutrals, disconnect the strap between the secondary neutral bushing and the tank. The primary and secondary neutral ground rods should be spaced a minimum of 6 feet apart; however, some states, such as Wisconsin, amend this code and require additional spacing to aid in isolation.
- 3) The secondary grounding conductor should have 600 volt insulation; a requirement of the National Electric Safety Code (NESC).
- 4) The telephone utility serving the customer should be consulted to assure that the telephone conductor shield does not effectively provide a direct connection between the primary and secondary neutral systems intended to be separated. This also applies to any other utility services that may be present (such as cable TV, etc.), causing the isolator to be by-passed.
- (5) Following installation, measurements should be taken to assure proper installation and functioning of the isolator.
- 6) Reference Figure 1 for installation with a typical pole-type transformer with a 120/240 volt secondary.
- 7) Note: Any time there is a blown transformer fuse or lightning-caused damage of any nearby utility or on-farm equipment, it is recommended that the isolator be checked for proper functioning. Should the isolator be exposed to currents above rating such that failure would occur, failure will normally occur in the shorted mode thereby permanently reconnecting the primary and secondary neutrals. (The DC resistance between terminals of a functioning unit should be more than 5000 Ohms—and will typically be much more—and the DC resistance of a failed unit will typically be less than one Ohm.) One lead should be removed when conducting this test. If there is a question regarding proper functioning, consult Dairyland Electrical Industries.



WARNING

Separating the primary and secondary neutral at a transformer is a nonstandard but accepted operating procedure per the National Electrical Safety Code (NESC) Rule 97D2. The specific instructions for installation of this product are to be provided by the utility so that all work is done in a safe manner and in accordance with the installing utility's practices and procedures. The following instructions are general in nature and are not intended as substitute for adequate training and experience in working around high-voltage electrical equipment.

Pad-Mount Transformer Installation

All of the above steps apply to the installation procedure for a pad-mount transformer except that in step one the isolator will normally be installed in a secondary type pedestal next to the transformer as shown in Figure 2, or in the transformer cable training area.

Three-phase pole mount installation

A three-phase pole mounted transformer installation will be similar to a single phase pole mount. Each transformer must have the secondary neutral bushing grounding strap removed, as not to be a bypass around the VTNI. Each tank remains bonded to the primary system grounding electrode and neutral. The VTNI should connect between the primary neutral and the secondary neutral of the three phase system.

Three-phase pad mount installation

In concept, a three-phase padmount transformer is the same as a pole mount installation, with one notable exception. The bond between the primary neutral and secondary neutral of a wye-wye transformer is often under oil internal to the tank, and may or may not have a removeable link that the utility can access. In order to allow electrical isolation of the primary and secondary neutrals, the transformer must have neutral link that is accessible and can be opened. The VTNI then externally connects between the primary and secondary neutrals as the bonding/isolating device in place of the internal link. This may require changeout of a pad mount transformer on site that does not have such an accessible link with one so equipped.

Multiple customer services

A utility customer that has more than one utility service, and desires primary-to-secondary neutral isolation, must have a VTNI installed at each service with the appropriate installation methods described above. Failure to address all services may result in a solid bond remaining between the utility neutral and customer neutral/grounds via the interconnected bonds and grounds within the customer facility.



FIGURE 1: Neutral Isolator Installation for 120/240V Single-Phase Pole-Mount Transformer

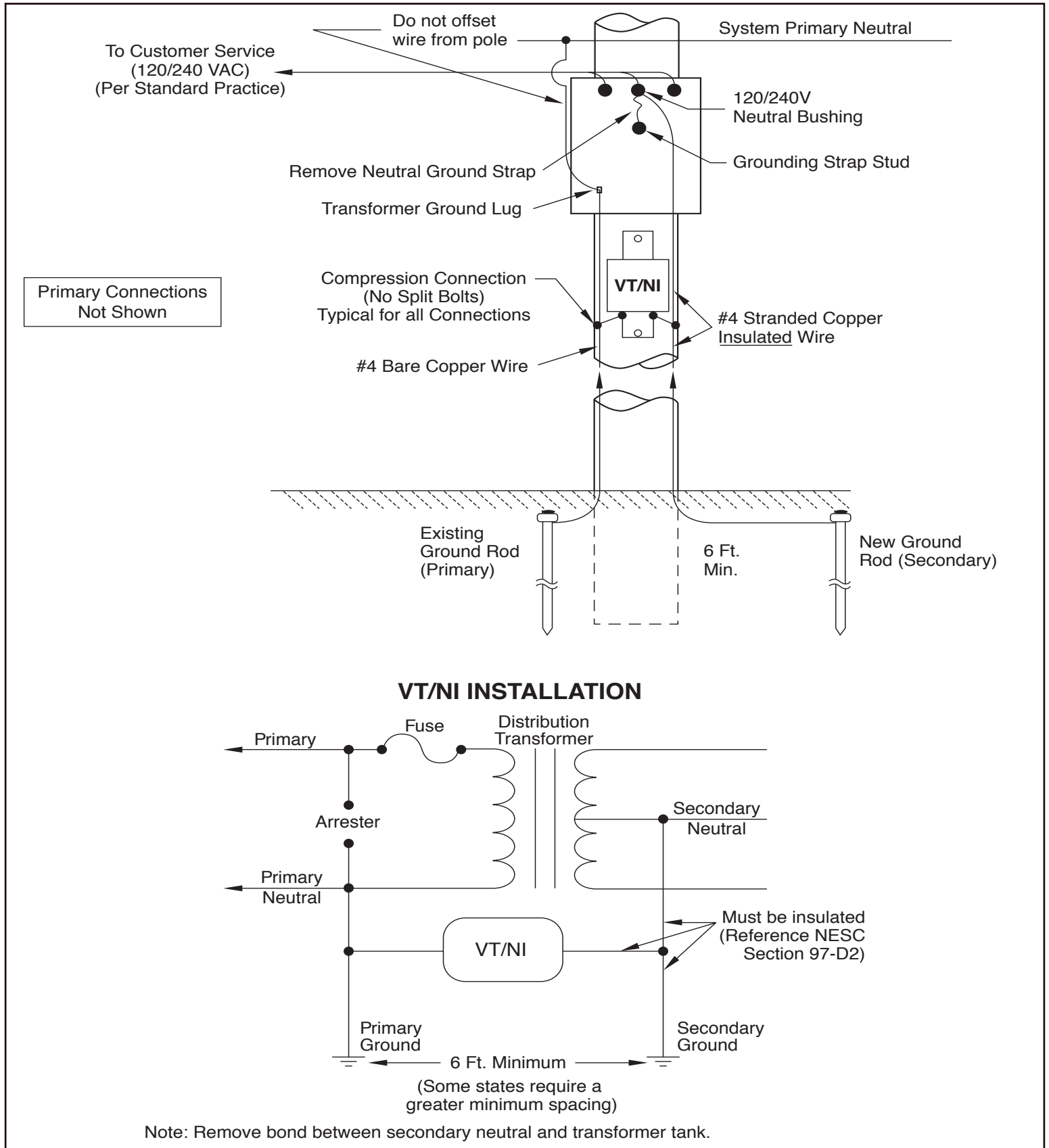
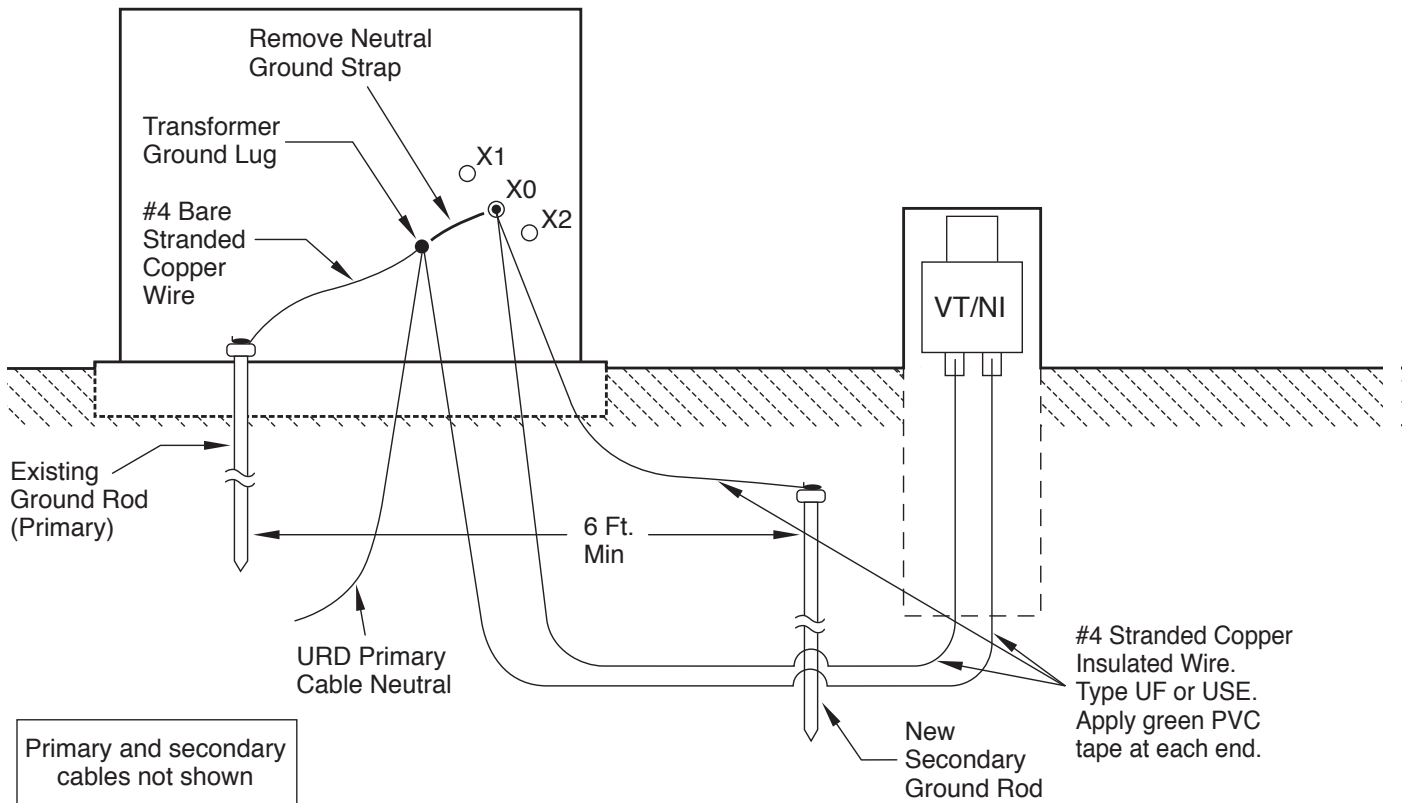
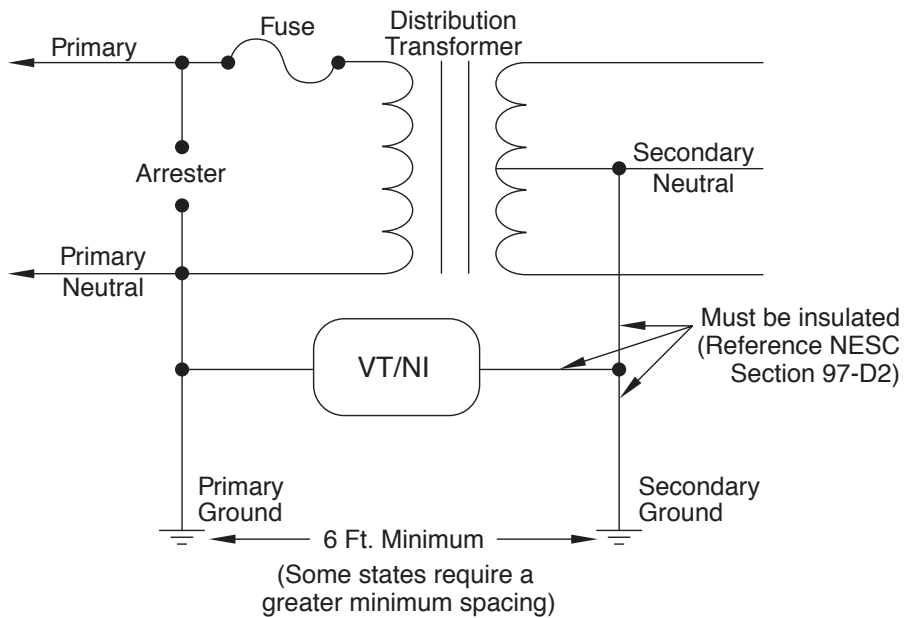



FIGURE 2: Neutral Isolator Installation for 120/240V Single-Phase Pad-Mount



VT/NI INSTALLATION



Note: Remove bond between secondary neutral and transformer tank.

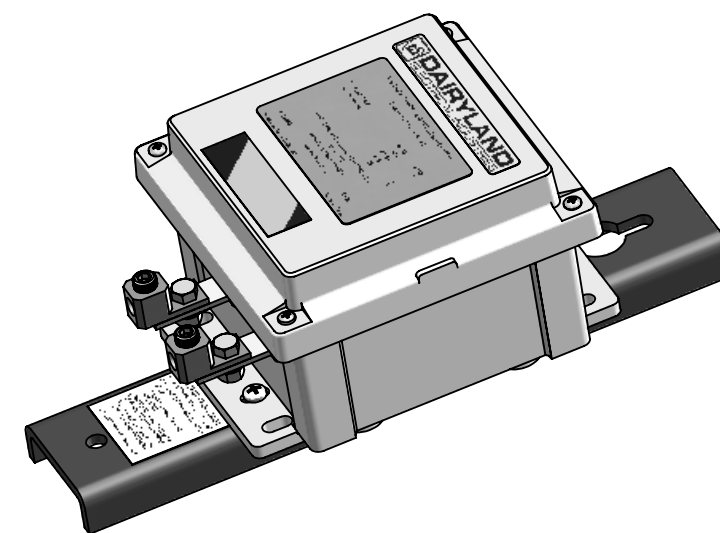
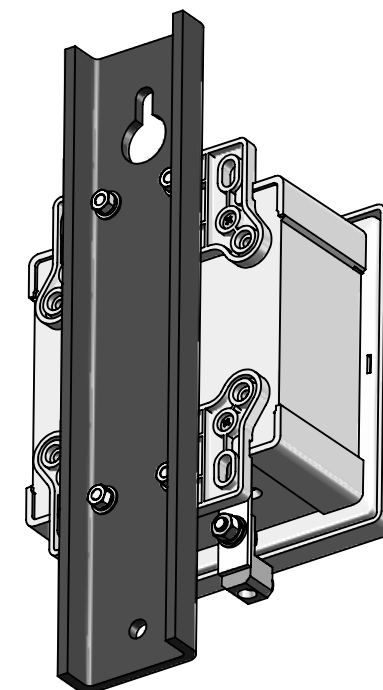
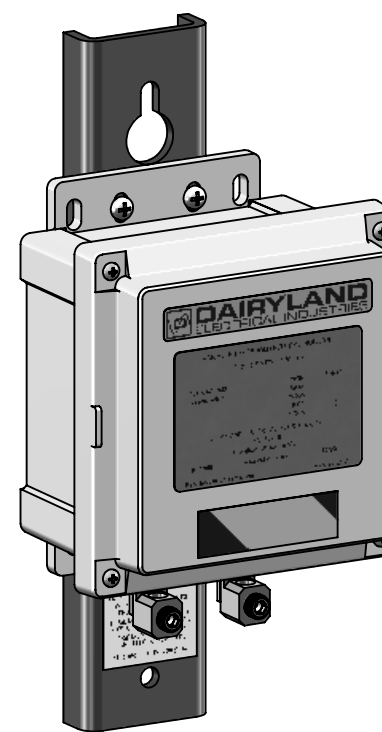
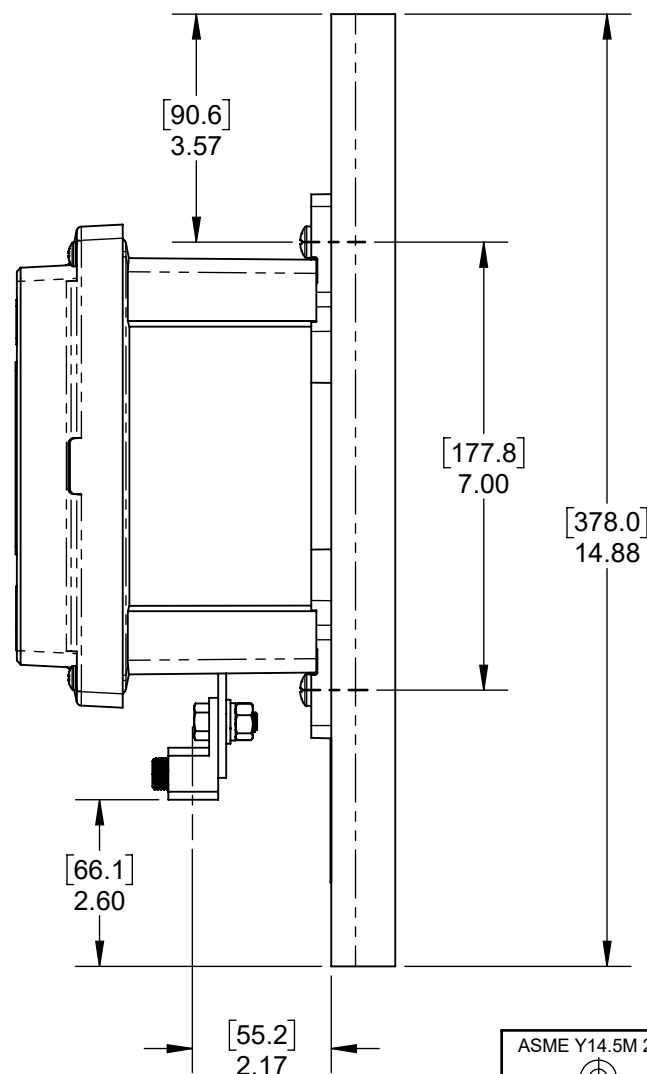
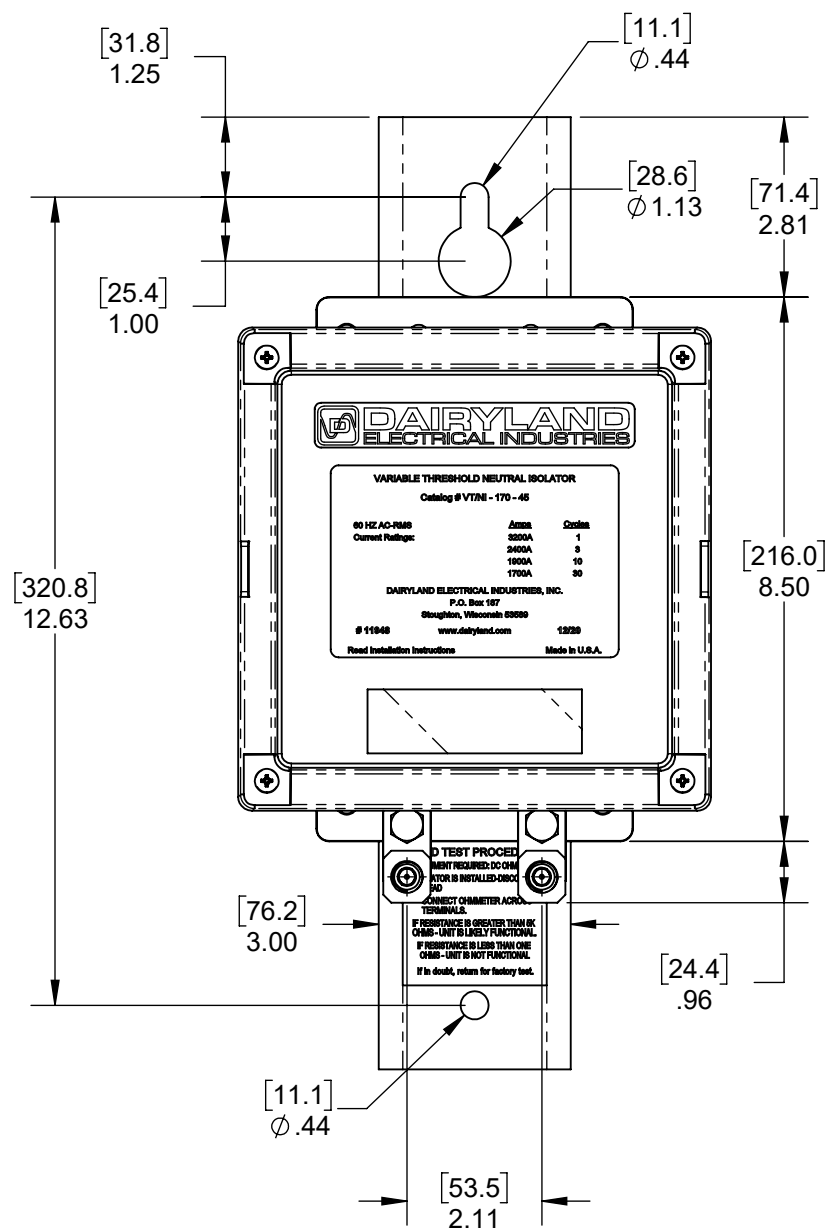
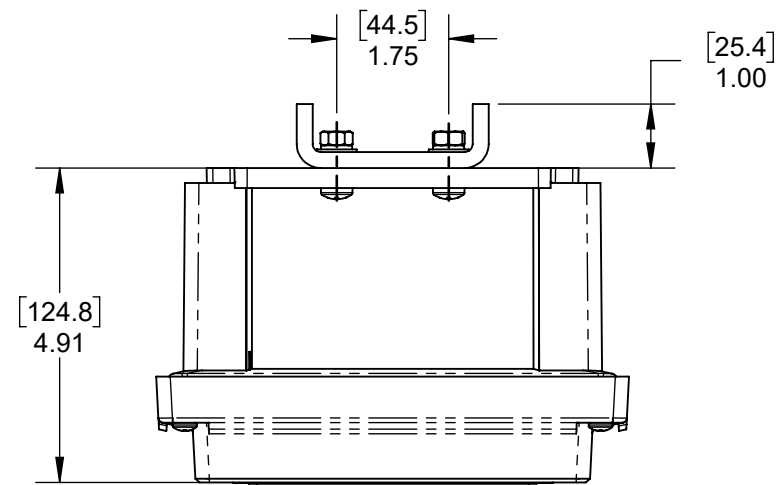

ASME Y14.5M 2018 APPLIES UNLESS OTHERWISE SPECIFIED DIMENSIONS ARE IN INCHES. COMPUTER-GENERATED DRAWING DO NOT EDIT MANUALLY. .XXX = ±.005" .XX = ±.01" .X = ±.03" ANGLES = ±1°	MATERIAL: NA	DRAWN: JPW	DATE DRAWN: 2015-08-18	 DAIRYLAND ELECTRICAL INDUSTRIES, INC. P.O. BOX 187 STOUGHTON, WI 53589 608-877-9900 DAIRYLAND.COM
	FINISH: NA	DWG APPROVAL: RJH	DATE APPROVAL: 09/13/2021	
THE INFORMATION CONTAINED IN THIS DRAWING IS THE SOLE PROPERTY OF DAIRYLAND ELECTRICAL INDUSTRIES, INC. ANY REPRODUCTION IN PART OR WHOLE, WITHOUT THE WRITTEN PERMISSION OF DAIRYLAND ELECTRICAL INDUSTRIES, INC. IS PROHIBITED.		TITLE: VTNI OUTLINE DRAWING		
SHEET: 1 OF 1		DWG SIZE: B	SCALE: 1:3	REV: B PART #: 100088