



**BRINGING NEW SOLUTIONS TO THE SURFACE.**

**SCOTCH-BRITE™ NONWOVEN ABRASIVES PRODUCT GUIDE**  
Interactive Digital Version



## TABLE OF CONTENTS

▶ Technology	2
▶ Applications	3
▶ System Configurations and Safe Operating	10
▶ Automation	14
▶ Nonwoven Abrasives	16
▶ Tools and Accessories	47
▶ Safety (PPE)	51



DOWNLOAD  
**3M Abrasives Product Catalog**



LEARN MORE AT:  
**3M.com/ScotchBriteAbrasives**



/3MAbrasives



/3MAbrasives



/3MAbrasives

# IMPROVE SURFACES WITH EASE.



## LASTS LONG, FINISHES STRONG.

Thick nonwoven fiber and integrated abrasive grains keep Scotch-Brite™ products performing like new throughout the life of the product.



## REPEATABLE RESULTS.

Whether you're cleaning, deburring or finishing, operators can easily achieve consistent, repeatable results with Scotch-Brite™ abrasives.

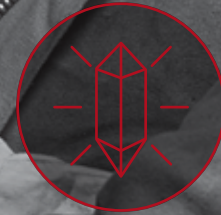

## UNCOMPROMISING QUALITY.

To get the best finish, you need the best abrasives. Scotch-Brite™ abrasives are continually improved to deliver uncompromising quality.

Decade after decade. Part after part. There's one family of abrasives that's trusted to deliver repeatable results and fine finishes, and that's Scotch-Brite™. With roots in the past and an eye on the future, Scotch-Brite™ Nonwoven Abrasives are dedicated to uncompromising quality — just like you.

## Check out this additional content!

VISIT AND SUBSCRIBE  
TO OUR 3M ABRASIVES  
YOUTUBE CHANNEL



Look for Video  
Icons like these  
throughout this  
catalog!

Check out our  
EVER FORWARD  
video! (48 SEC)



## TIP

INTERACTIVE LINKS throughout this catalog give you instant access to additional information. CLICK or TAP these icons in the PDF!



Play



Download



Link

# THE SCIENCE BEHIND HIGH-QUALITY FINISHES.

## SCOTCH-BRITE™ NONWOVEN WEB TECHNOLOGY

The nonwoven web technology from Scotch-Brite™ is made with nylon that has been soaked in resin and abrasive mineral. The fibers and particles are bound together to form an open, three-dimensional structure. This construction provides spring-like action, which helps the product conform and bounce back without leaving an uneven finish.

Whether hand pads, discs, wheels or belts, the material is consistent all the way through. This means new abrasive mineral is exposed while you work, helping to extend the life of your abrasive product so that you can keep producing consistent finishes.

With Scotch-Brite™ nonwoven abrasives, grade is generally used to describe the finish attributes — the coarser the grade, the more aggressive cut and finish.

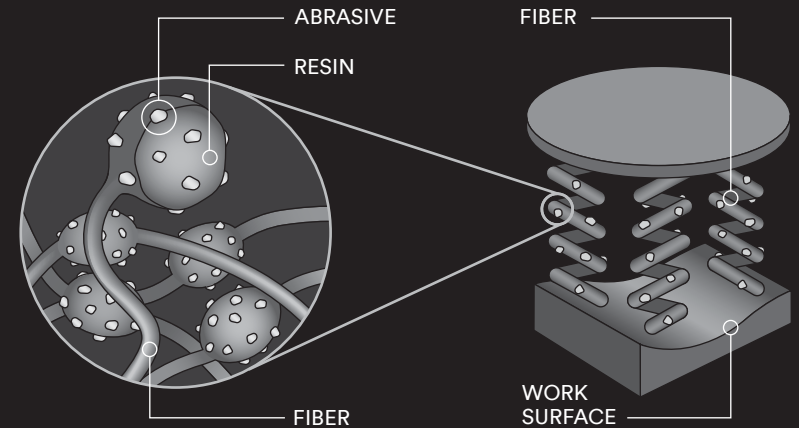

3D OPEN WEB

SPRING ACTION

### What's the difference between these abrasive materials?

**Aluminum Oxide** is exceedingly durable, providing long life as the mineral breaks down at a slower rate — commonly used for a wide range of applications.

**Silicon Carbide** is a synthetic mineral that is very sharp with a narrow shape, which wears down faster and is commonly used for low-pressure applications.

**3M Precision-Shaped Grain** is a triangular-shaped ceramic grain that is designed with sharp, angular structures that continuously fracture to form new sharp cutting edges.

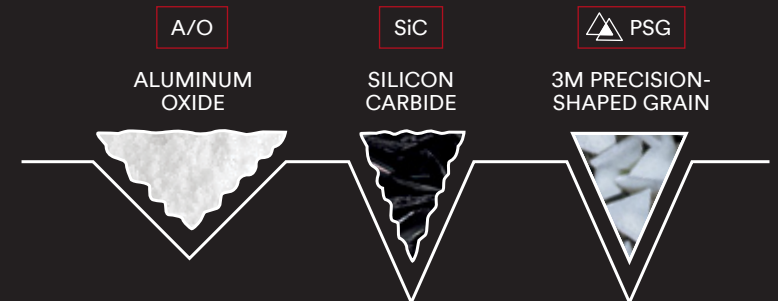

# APPLICATIONS

Scotch-Brite™ Nonwoven Abrasives are designed with conformable, high-strength fibers that deliver quick and consistent performance. Each product brings a safe, reliable solution to the job. **Which one is right for you?**

SCOTCH-BRITE™ IS HERE FOR YOU EVERY STEP OF THE WAY.

## 1 CLEANING / SURFACE PREP

To achieve an attractive finished product, surface preparation is a crucial step in the metalworking process. Scotch-Brite™ products are designed to make quick work of paint removal, rust removal, scratch refinement and other surface preparation tasks.

Explore the products that will work for your application: [Pages 4–5](#) ▶

## 2 DEBURRING

Deburring is the process of smoothing out the imperfections of rough/sharp edges. With metal burrs and edges on every stamped and lasered metal part, deburring is a key step. Scotch-Brite™ solutions offer a wide selection of deburring abrasives for metalworking projects of any size or shape.

Explore the products that will work for your application: [Page 6](#) ▶

## 3 BLENDING

Blending is the process of making different surface finishes appear more uniform. Scotch-Brite™ nonwoven products will leave a smooth, burr-free surface.

Explore the products that will work for your application: [Page 7](#) ▶

## 4 FINISHING / POLISHING PREP

Finishing is the process of improving the finish of a component, which then may be different from the original finish. Further blending may be needed so the finishes are more similar. Scotch-Brite™ products deliver consistent, repeatable finishes in many industries.

Explore the products that will work for your application: [Pages 8–9](#) ▶

# TOOLS

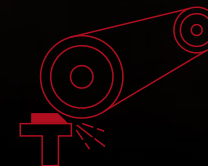
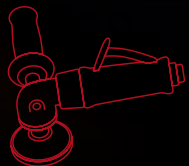

Match with the right tools and accessories to ensure you get the highest performance out of your Scotch-Brite™ Nonwoven Abrasives.



1



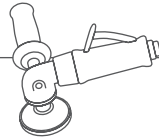
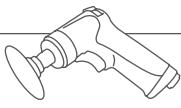
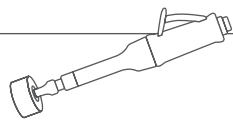
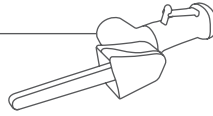

# CLEANING / SURFACE PREP

Match the application to the tool you will be using to find the recommended Scotch-Brite™ Nonwoven Abrasives. **CLICK** or **TAP** the product to go directly to that page.

 <p><b>Disc Sander</b> Right Angle System</p>	 <p><b>Disc Sander</b> 3M™ Roloc™ System</p>	 <p><b>Die Grinder</b></p>	 <p><b>File Belt</b></p>	 <p><b>Hand Sanding</b></p>
--	---	---	---	--





## WELD CLEANING / DISCOLORATION



 <p>Scotch-Brite™ Clean and Strip XT Pro Extra Cut Discs</p>	 <p>Scotch-Brite™ Roloc™ Clean and Strip XT Pro Extra Cut Discs</p>	 <p>Scotch-Brite™ Precision Radial Bristle Brush, TC 80+</p>	 <p>Scotch-Brite™ Durable Flex Surface Conditioning Belts</p>	 <p>Scotch-Brite™ Heavy Duty Hand Pad 7440</p>
---	--	---	--	---

## PAINT / RUST / SCALE REMOVAL



 <p>Scotch-Brite™ Clean and Strip XT Pro Discs</p>	 <p>Scotch-Brite™ Roloc™ Clean and Strip XT Pro Discs</p>	 <p>Scotch-Brite™ Roloc™ Clean and Strip XT Pro Discs</p>	 <p>Scotch-Brite™ Durable Flex Surface Conditioning Belts</p>	 <p>Scotch-Brite™ Heavy Duty Hand Pad 7440</p>
---	--	--	--	---

1

# CLEANING / SURFACE PREP

Match the application to the tool you will be using to find the recommended Scotch-Brite™ Nonwoven Abrasives. **CLICK** or **TAP** the product to go directly to that page.

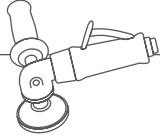
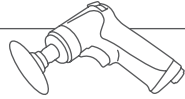
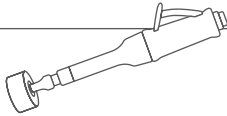
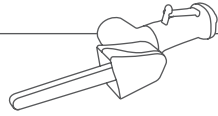
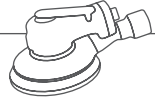
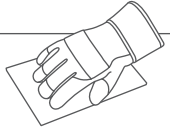
					
<b>Disc Sander</b> Right Angle System	<b>Disc Sander</b> 3M™ Roloc™ System	<b>Die Grinder</b>	<b>File Belt</b>	<b>Random Orbital Sanding</b>	<b>Hand Sanding</b>







## PAINT / BONDING / SCUFFING PREP (CLEANING SURFACE / REMOVING)

						
<b>Scotch-Brite™ Precision and Precision Heavy Duty Surface Conditioning Discs</b>	<b>Scotch-Brite™ Precision and Precision Heavy Duty Surface Conditioning Discs</b>	<b>Scotch-Brite™ Roloc™ Precision and Precision Heavy Duty Surface Conditioning Discs</b>	<b>Scotch-Brite™ Precision Radial Bristle Brushes and Discs</b>	<b>Scotch-Brite™ Durable Flex Surface Conditioning Belts</b>	<b>Scotch-Brite™ Disc 7447 Pro</b>	<b>Scotch-Brite™ Hand Pad 7447 Pro</b>

## SEALANT / ADHESIVE REMOVAL

						
<b>Scotch-Brite™ Clean and Strip XT Pro Disc</b>	<b>Scotch-Brite™ Clean and Strip XT Pro Disc</b>	<b>Scotch-Brite™ Roloc™ Clean and Strip XT Pro Discs</b>	<b>Scotch-Brite™ Clean and Strip XT Pro Disc</b>	<b>Scotch-Brite™ Durable Flex Surface Conditioning Belts</b>		<b>Scotch-Brite™ Hand Pad 7447</b>

## WELD PREP

						
<b>Scotch-Brite™ Clean and Strip XT Pro Disc</b>	<b>Scotch-Brite™ Clean and Strip XT Pro Disc</b>	<b>Scotch-Brite™ Roloc™ Clean and Strip XT Pro Discs</b>	<b>Scotch-Brite™ Roloc™ Clean and Strip XT Pro Discs</b>	<b>Scotch-Brite™ Durable Flex Surface Conditioning Belts</b>		<b>Scotch-Brite™ Hand Pad 7447</b>

# DEBURRING

Match the application to the tool you will be using to find the recommended Scotch-Brite™ Nonwoven Abrasives. **CLICK** or **TAP** the product to go directly to that page.

 <p><b>Disc Sander</b> Right Angle System</p>	 <p><b>Disc Sander</b> 3M™ Roloc™ System</p>	 <p><b>Die Grinder</b></p>	 <p><b>File Belt</b></p>	 <p><b>Belts</b></p>
--	---	---	---	---

## MACHINE EDGE RADIUS / EDGE BREAKING



**Scotch-Brite™ Precision and Precision Heavy Duty Surface Conditioning Discs**



**Scotch-Brite™ Roloc™ Deburr and Finish PRO Unitized Wheels 6C MED+**



**Scotch-Brite™ Precision Radial Bristle Brush TC 80+**



**Scotch-Brite™ Durable Flex Surface Conditioning Belts**



**Scotch-Brite™ SE Surface Conditioning Belts**

## MICRO BURR

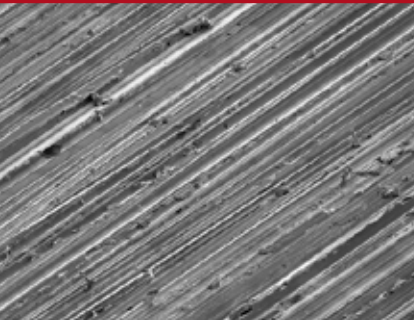

**Scotch-Brite™ Precision Surface Conditioning Discs**



**Scotch-Brite™ Roloc™ Precision Surface Conditioning Discs**

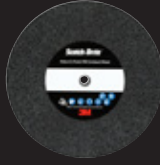

**Scotch-Brite™ Deburr and Finish PRO Unitized Wheels 2S FIN**



**Scotch-Brite™ Durable Flex Surface Conditioning Belts**



**Scotch-Brite™ SC Surface Conditioning Belts**

## PIPE THREAD / GEAR DEBURRING / BURR REMOVAL



**Scotch-Brite™ Deburr and Finish PRO Unitized Wheels 8C CRS+**



**Scotch-Brite™ Roloc™ Deburr and Finish PRO Unitized Wheels 8C CRS+**



**Scotch-Brite™ Deburr and Finish PRO Unitized Wheels 6C MED+**





**Scotch-Brite™ Durable Flex Surface Conditioning Belts**

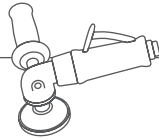
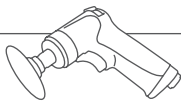
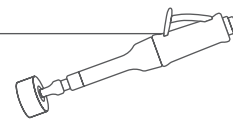
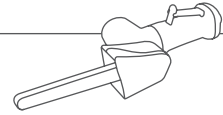
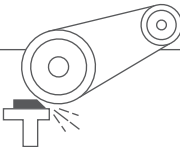

# BLENDING

Match the application to the tool you will be using to find the recommended Scotch-Brite™ Nonwoven Abrasives. **CLICK** or **TAP** the product to go directly to that page.

					
<b>Disc Sander</b> Right Angle System	<b>Disc Sander</b> 3M™ Roloc™ System	<b>Die Grinder</b>	<b>File Belt</b>	<b>Belts</b>	<b>Hand Sanding</b>



## WELD BLENDING

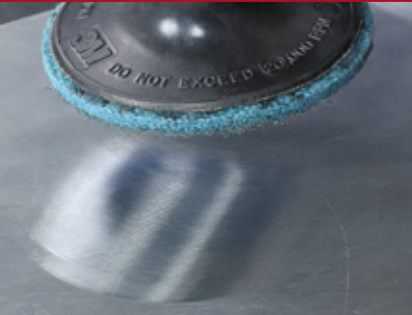

					
<b>Scotch-Brite™ Precision Heavy Duty Surface Conditioning Discs</b>	<b>Scotch-Brite™ Roloc™ Precision Heavy Duty Surface Conditioning Discs</b>	<b>Scotch-Brite™ Deburr and Finish PRO Unitized Wheels 8C CRS+</b>	<b>Scotch-Brite™ Durable Flex Surface Conditioning Belts</b>	<b>Scotch-Brite™ SE Surface Conditioning Belts</b>	

## SCRATCH REFINEMENT / PAINT PREPARATION

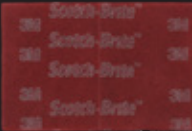

					
<b>Scotch-Brite™ Precision and Precision Heavy Duty Surface Conditioning Discs</b>	<b>Scotch-Brite™ Roloc™ Precision and Precision Heavy Duty Surface Conditioning Discs</b>	<b>Scotch-Brite™ Deburr and Finish PRO Unitized Wheels 8C CRS+</b>	<b>Scotch-Brite™ Durable Flex Surface Conditioning Belts</b>	<b>Scotch-Brite™ SC Surface Conditioning Belts</b>	<b>Scotch-Brite™ Hand Pad 7447 Pro</b>



## PARTING LINE REMOVAL



					
<b>Scotch-Brite™ Precision and Precision Heavy Duty Surface Conditioning Discs</b>	<b>Scotch-Brite™ Roloc™ Precision and Precision Heavy Duty Surface Conditioning Discs</b>	<b>Scotch-Brite™ Cut and Polish Flap Brushes CPFBS and CPFBR+</b>	<b>Scotch-Brite™ Durable Flex Surface Conditioning Belts</b>	<b>Scotch-Brite™ SE Surface Conditioning Belts</b>	<b>Scotch-Brite™ Hand Pad 7447 Pro</b>



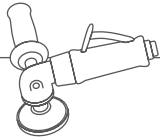
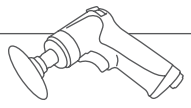
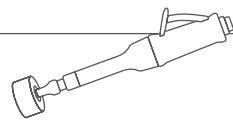
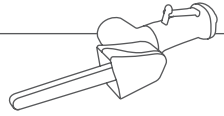
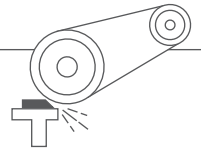

# FINISHING / POLISH PREP

Match the application to the tool you will be using to find the recommended Scotch-Brite™ Nonwoven Abrasives. **CLICK** or **TAP** the product to go directly to that page.

 <p><b>Disc Sander</b> Right Angle System</p>	 <p><b>Disc Sander</b> 3M™ Roloc™ System</p>	 <p><b>Die Grinder</b></p>	 <p><b>File Belt</b></p>	 <p><b>Belts</b></p>	 <p><b>Hand Sanding</b></p>
--	---	--	---	---	--

## SETTING THE GRAIN

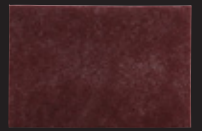

		 <p><b>Scotch-Brite™ Metal Finishing Wheels A MED</b> Also works for radial finishing sander and bench motor</p>	 <p><b>Scotch-Brite™ Durable Flex Surface Conditioning Belts</b></p>	 <p><b>Scotch-Brite™ SC Surface Conditioning Belts</b></p>	 <p><b>Scotch-Brite™ Hand Pad 7447</b></p>
---	---	--	---	---	---



## SURFACE REFINEMENT



 <p><b>Scotch-Brite™ Precision Surface Conditioning Discs</b></p>	 <p><b>Scotch-Brite™ Roloc™ Precision Surface Conditioning Discs</b></p>	 <p><b>Scotch-Brite™ Cut and Polish Wheels</b></p>	 <p><b>Scotch-Brite™ Durable Flex Surface Conditioning Belts</b></p>	 <p><b>Scotch-Brite™ SC Surface Conditioning Belts</b></p>	 <p><b>Scotch-Brite™ Hand Pad 7447</b></p>
--	---	--	---	---	---



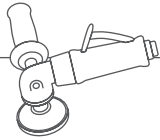
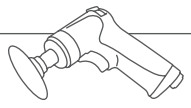
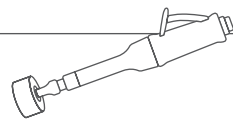
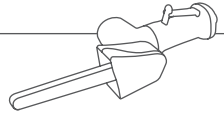
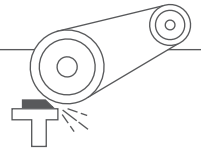

# FINISHING / POLISH PREP

Match the application to the tool you will be using to find the recommended Scotch-Brite™ Nonwoven Abrasives. **CLICK** or **TAP** the product to go directly to that page.

 <p><b>Disc Sander</b> Right Angle System</p>	 <p><b>Disc Sander</b> 3M™ Roloc™ System</p>	 <p><b>Die Grinder</b></p>	 <p><b>File Belt</b></p>	 <p><b>Belts</b></p>	 <p><b>Hand Sanding</b></p>
--	---	--	---	---	--

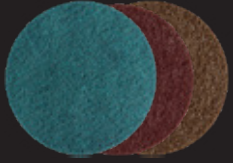

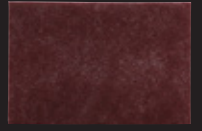

## AESTHETIC / FLAT PART FINISHING



 <p><b>Scotch-Brite™ SC Surface Conditioning Discs</b></p>	 <p><b>Scotch-Brite™ Roloc™ SC Surface Conditioning Discs</b></p>	 <p><b>Scotch-Brite™ Multi-Finishing Wheels</b></p> <p>Also works for radial finishing sander and bench motor</p>	 <p><b>Scotch-Brite™ Durable Flex Surface Conditioning Belts</b></p>	 <p><b>Scotch-Brite™ SC Surface Conditioning Belts</b></p>	 <p><b>Scotch-Brite™ Hand Pad 7447</b></p>
---	--	---	---	---	---

## BUFFING / POLISHING

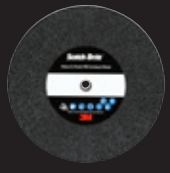
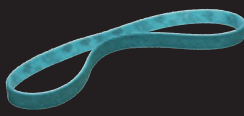

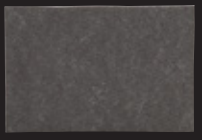
 <p><b>Scotch-Brite™ SC Surface Conditioning Disc</b> A VFN</p>	 <p><b>Scotch-Brite™ Roloc™ Deburr and Finish PRO Unitized Wheel</b> 2S FIN</p>	 <p><b>Scotch-Brite™ Deburr and Finish PRO Unitized Wheel</b> 2S FIN</p>	 <p><b>Scotch-Brite™ SC Surface Conditioning File Belt</b> A VFN</p>	 <p><b>Scotch-Brite™ SC Surface Conditioning Belt</b> A VFN</p>	 <p><b>Scotch-Brite™ Hand Pad 7448</b></p>
--	--	--	---	--	---

# SYSTEM CONFIGURATIONS

Tool + Accessories + Scotch-Brite™ Nonwoven Abrasive = Optimized System

## 3M™ DISC SANDER | RIGHT ANGLE SYSTEM

### Universal Backup Pad

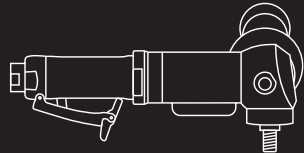

Scotch-Brite™ Universal Backup Pad



Adapter Nut  
M14 / M10 / 5/8–11 Thread



Center Post (Optional)



Scotch-Brite™ Nonwoven Abrasive Disc with Hook and Loop



### Hook and Loop

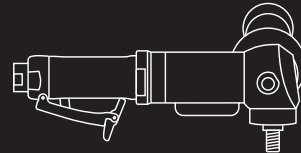

3M™ Hook and Loop Disc Pad Holder



Scotch-Brite™ Nonwoven Abrasive Disc with Hook and Loop



### Threaded 5/8–11

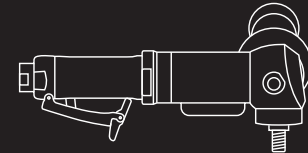

Scotch-Brite™ Nonwoven Abrasive Disc with 5/8–11 threaded attachment



### TN Quick Change

#### 1-piece 4-1/2 Attachment System

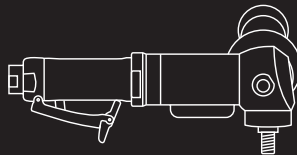

TN Quick Change Disc Backup Pad



Scotch-Brite™ Nonwoven Abrasive Disc TN Quick change attachment



#### 2-piece Attachment System

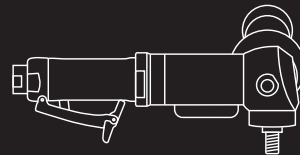

3M™ Disc Pad Hub



3M™ Disc Pad Face Plate



Scotch-Brite™ Nonwoven Abrasive Disc TN Quick change attachment



### 7/8 Center Hole

#### 1-piece Attachment System

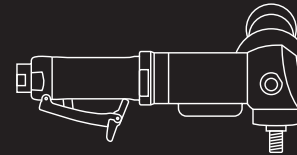

Flap Disc / Grinding Wheel Adapter Nut 5/8–11 Thread



Scotch-Brite™ Nonwoven Abrasive Disc Type 27 (7/8 Center Hole)



Flap Disc / Grinding Wheel Adapter Nut 5/8–11 Thread



#### 3-piece Attachment System

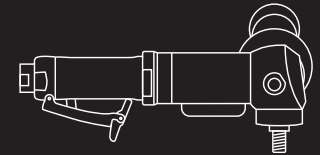

3M™ Disc Pad Hub



3M™ Disc Pad Face Plate



Scotch-Brite™ Nonwoven Abrasive Disc with 7/8 Center Hole



3M™ Disc Retainer Nut



# SYSTEM CONFIGURATIONS

Tool + Accessories + Scotch-Brite™ Nonwoven Abrasive = Optimized System

## 3M™ ELECTRIC ANGLE GRINDER

### Universal Backup Pad

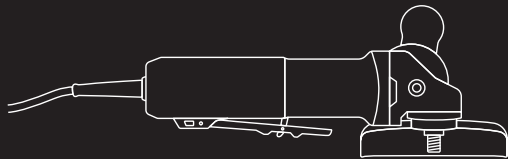

Scotch-Brite™ Universal Backup Pad



Adapter Nut  
M14 / M10 / 5/8–11 Thread



Center Post (Optional)



Scotch-Brite™ Nonwoven Abrasive Disc with Hook and Loop



### Hook and Loop

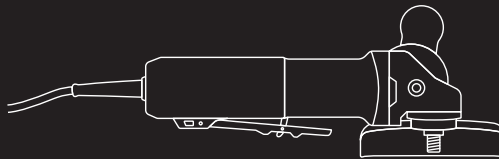

3M™ Hook and Loop Disc Pad Holder



Scotch-Brite™ Nonwoven Abrasive Disc with Hook and Loop



### Threaded 5/8–11

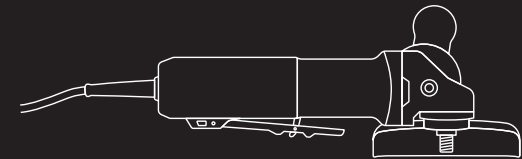

Scotch-Brite™ Nonwoven Abrasive Disc with 5/8–11 threaded attachment

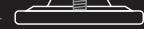

### TN Quick Change

#### 1-piece 4-1/2 Attachment System

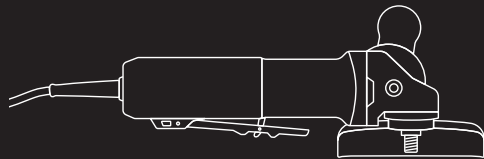

TN Quick Change Disc Backup Pad



Scotch-Brite™ Nonwoven Abrasive Disc TN Quick change attachment



#### 2-piece Attachment System

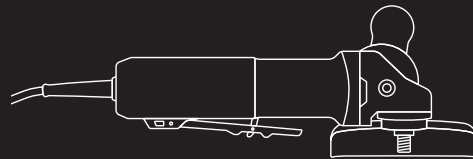

3M™ Disc Pad Hub



3M™ Disc Pad Face Plate Ribbed



Scotch-Brite™ Nonwoven Abrasive Disc TN Quick change attachment



### 7/8 Center Hole

#### 1-piece Attachment System

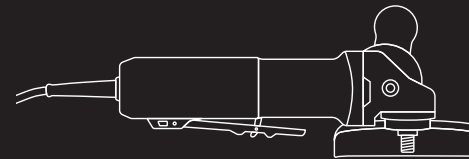

Flap Disc / Grinding Wheel Adapter Nut 5/8–11 Thread



Scotch-Brite™ Nonwoven Abrasive Disc Type 27 (7/8 Center Hole)



Flap Disc / Grinding Wheel Adapter Nut 5/8–11 Thread



#### 3-piece Attachment System

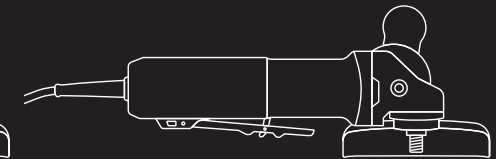

3M™ Disc Pad Hub



3M™ Disc Pad Face Plate Ribbed



Scotch-Brite™ Nonwoven Abrasive Disc with 7/8 Center Hole



3M™ Disc Retainer Nut





# SYSTEM CONFIGURATIONS

Tool + Accessories + Scotch-Brite™ Nonwoven Abrasive = Optimized System

## 3M™ DISC SANDER

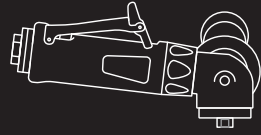
### 3M™ Roloc™ System



Sander Adapter 

3M™ Roloc™ Disc Pad 

Scotch-Brite™ Roloc™ Nonwoven Abrasive Disc 

## 3M™ DIE GRINDER

### 3M™ Roloc™+ System



3M™ Roloc™+ Holder 

Scotch-Brite™ Roloc™+ Nonwoven Abrasive Disc Wheel or Brush 

### Collet Attachment System

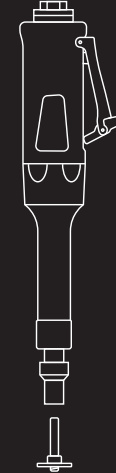

Mandrel 

Scotch-Brite™ Nonwoven Abrasive Wheel 

Mandrel Cap 

## 3M™ INLINE SANDER

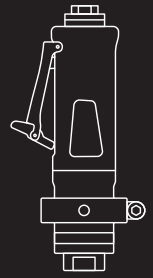

Adapter Kit 

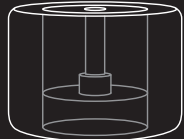
Rubber Slotted Expander Wheel 

Adapter Kit Cap 

Scotch-Brite™ Nonwoven Abrasive Belt 

## 3M™ FILE BELT SANDER



Attachment Arm 

Scotch-Brite™ File Belt 

## 3M™ RANDOM ORBITAL SANDER



3M™ Hookit™ Low Profile Disc Pad 

Scotch-Brite™ Hookit™ Disc 

## 3M™ MATCH AND FINISH SANDER

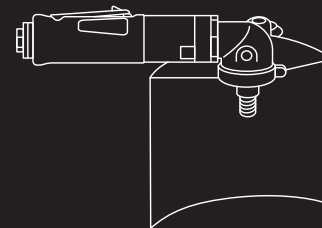

Scotch-Brite™ Nonwoven Abrasive Flap Brush 

# SAFE OPERATING

## STAY SMART. STAY SAFE. STAY WITH SCOTCH-BRITE™

Always check to make sure the tool or machine does not run faster than the maximum operating speed (Max. RPM) of the consumable (disc, wheel, belt) or when applicable, the backup pad accessory.

Certain Scotch-Brite™ Nonwoven Abrasives do not have a speed rating. Therefore, the Max. RPM of the backup pad should be used. Always use proper backup pads with discs. Select a back up pad that is compatible with and the same size as the disc being used.

**Exceeding the product's Max. RPM can cause it to break apart and cause serious injury.**

### EXAMPLE



3M™ Roloc™ Disc Pad  
Max. RPM: 20,000



Scotch-Brite™ Roloc™  
Nonwoven Abrasive Disc  
Max. RPM: 18,000

**DO NOT EXCEED 18,000 RPM**

### SAFETY ICONS ARE LOCATED ON THE ABRASIVE, LABEL OR PACKAGE AND MAY VARY BY PRODUCT.

Scotch-Brite™ Precision Surface Conditioning Discs



Scotch-Brite™ Clean and Strip XT Pro Extra Cut Discs



**NEVER EXCEED THE MAX. RPM SPEED** of the abrasive (disc, wheel, belt) or when applicable, the backup pad accessory.



**PROTECT HANDS**  
Always wear safety gloves.



**PROTECT LUNGS**



**PROTECT EARS**  
Protect your hearing.



**PROTECT EYES**  
Wear safety goggles.



**READ INSERT** before mounting or using product.



**PROTECT BODY AND SKIN**

## Safety Icons

PREP		Read SDS before mounting or using product.
		Always wear ANSI Z87+ approved face shield. Safety goggles should always be worn with a face shield. Do not wear a face shield alone.
PROTECTION		Protect your eyes, ears and lungs. Always wear ANSI Z87+ approved face shield. Safety goggles and EPA labeled hearing protection and NIOSH approved respirators.
		Protect your hands. Always wear safety gloves.
		Body and Skin Protection
SAFE OPERATING		Check Max. RPM
		Inspect Wheel
		Abrasive product only for use with additional appropriate backup pad.
		Do not use a damaged abrasive wheel.
		Vibrating / wobbling wheel hazard.

## TECH TIP

## WHERE TO FIND MAX. OPERATING SPEEDS

**3M™ ROLOC™ DISCS**  
Max. RPM is located on the label or box.

**BELTS**  
6,500 SFPM.

**BRISTLE DISCS**  
Max. RPM is molded into the back of the disc.

**WHEELS / BRUSHES**  
Max. RPM is located on the label or box.

# ABRASIVES AUTOMATION AND ROBOTICS

3M offers abrasive solutions and expertise to help you automate a variety of material removal processes, from robotic grinding to robotic polishing and every step in-between.

Scotch-Brite™ products are ideally suited for robotic applications as they can help increase productivity, consistency and cost savings in automated processes.



**FOLLOW US INTO THE FUTURE**

From abrasives to automation, 3M continues to innovate, reinvent and reimagine industrial solutions for the metalworking industry.

# ABRASIVES AUTOMATION AND ROBOTICS

## COMMITMENT TO AUTOMATION SUCCESS.

Highly conformable Scotch-Brite™ Nonwoven Abrasives allow the abrasive to stay in contact with complex-shaped parts, while delivering consistent performance, making them ideal for robotic processing. Scotch-Brite™ solutions offer a wide range of long-lasting wheels, belts and brushes for automated applications.



**COMPLEX? SURE.  
DOABLE?  
ABSOLUTELY.**

3M has the expertise, connections and products to help you succeed.

GET STARTED — contact your 3M sales professional or get in touch with one of our application engineers at [3M.com/robotics](https://3M.com/robotics).

### APPLICATIONS USING SCOTCH-BRITE™ PRODUCTS

AUTOMATION				FIXED AUTOMATION	
ROBOTIC DEBURRING	ROBOTIC WELD GRINDING AND BLENDING	ROBOTIC SATIN FINISHING AND POLISHING	ROBOTIC CLEANING AND COATINGS REMOVAL	AUTOMATED FLAT FINISHING	AUTOMATED DEBURRING
Debur and Finish PRO Unitized Wheels EXL Unitized Wheels EXL Deburring Convolute Wheels Precision Radial Bristle Brushes and Discs Radial Bristle Brushes and Bristle Discs	Precision Surface Conditioning Discs Precision Heavy Duty Surface Conditioning Discs Surface Conditioning Discs Surface Conditioning Belts	Surface Conditioning Belts Metal Finishing Unitized Wheels Multi-Finishing Unitized Wheels Surface Conditioning Flap Brushes	Clean and Strip Discs Clean and Strip XT Pro Discs Precision Radial Bristle Discs Bristle Discs	Wide Brushes Surface Conditioning Long / Wide Belts	Brushes Surface Conditioning Belts



**Check out this additional content!**

Automation Toolkit



Automation Abrasives



Automation Customer Handbook



**LEARN MORE**

**HANDBOOK**

# NONWOVEN ABRASIVES

Scotch-Brite™ Nonwoven Abrasives allow you to achieve a uniform finish in fewer steps without damaging the base material.

Our full line of abrasives are available in a variety of grades to help you meet your deburring, sanding, blending, finishing and polishing requirements.

## COLOR CODING

Discs Page 18 ▶

Belts Page 37 ▶

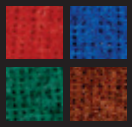

## TRIAL PACKS

Page 46 ▶



## SURFACE CONDITIONING DISCS

Pages 17–22 ▶



## CLEAN AND STRIP

Pages 23–24 ▶



## UNITIZED WHEELS

Pages 25–27 ▶



## CONVOLUTE WHEELS

Pages 28–31 ▶

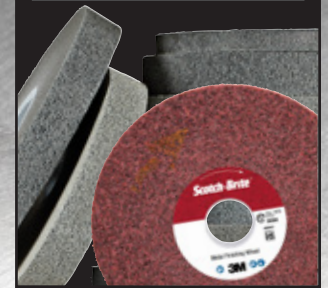

## FLATSTOCK AND HAND PADS

Pages 32–35 ▶

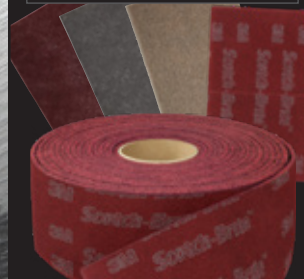

## BELTS

Pages 36–39 ▶



## BRUSHES

Pages 40–41 ▶



## MOLDED



Pages 42–45 ▶



# SCOTCH-BRITE™ SURFACE CONDITIONING DISCS

## CHOOSE THE RIGHT DISC FOR THE JOB.

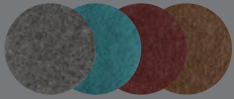
Scotch-Brite™ Surface Conditioning Discs can help with your first step for cleaning, blending, deburring and finishing without undercutting the base material. The durable open web is designed to resist loading — producing a high cut rate, consistent finish and extending operation.

SCOTCH-BRITE™ SURFACE CONDITIONING DISCS	GRADES	CONFORMABLE					DURABLE			SUBSTRATES	MINERAL
		POLISH	CLEAN	RADIUS	FINISH	REFINE	BLEND	DEBURR & EDGE BREAK	LIGHT GRINDING		
MULTI-PURPOSE: LOW PRESSURE	<b>Precision</b>  VFN CRS FIN XCRS MED	✓	✓	✓	✓	✓	✓	✓	✓	Can vary by grade Stainless Steel Aluminum Mild Steel Titanium Nickel Alloys	 PSG 3M Precision-Shaped Grain
	<b>SC</b>  SFN MED VFN CRS	✓	✓	✓	✓	✓	✓			Stainless Steel Aluminum Mild Steel Titanium Nickel Alloy	 A/O + SiC Aluminum oxide/Silicon carbide
HEAVY DUTY: HIGH PRESSURE	<b>Precision Heavy Duty</b>  MED 150+ CRS 120+ XCRS 80+ XXCRS 60+						✓	✓	✓	Aluminum Mild Steel Stainless Steel Copper Nickel Alloy	 PSG 3M Precision-Shaped Grain
	<b>SE</b>  FIN CRS MED					✓	✓	✓		Stainless Steel Aluminum Mild Steel	 A/O Aluminum oxide







## MAKE TOUGH JOBS EASIER.

Scotch-Brite™ Surface Conditioning Discs can help you achieve a burr-free, paintable finish in fewer steps without damaging the base material. The nonwoven, open web and durable construction is designed to resist loading and greatly increase the life of the disc.

## Check out this additional content!

Watch how Scotch-Brite™ discs complete these jobs!

-  **GRINDING** (2:31 MIN)
-  **BLENDING** (1:46 MIN)
-  **REFINING** (2:17 MIN)
-  **CLEANING** (1:31 MIN)

Find the right disc for your job



Watch a product demo video!

-  **DEMO** (1:38 MIN)

Surface Conditioning Discs Portfolio



WATCH VIDEOS

RESOURCES

# CRACKING THE COLOR CODE — DISCS

HAVE CONFIDENCE THAT YOU ARE USING THE REAL DEAL.

Recognizing the authentic Scotch-Brite™ Brand colors can help you to quickly identify quality nonwoven abrasives — and their grades.<sup>1</sup>

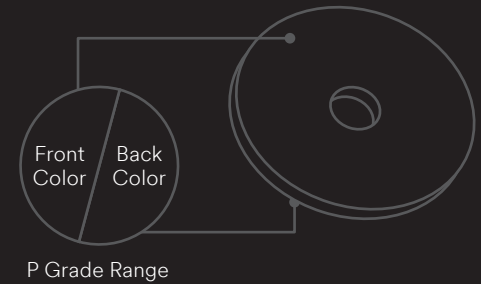







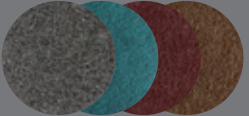
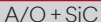

Scotch-Brite™ Surface Conditioning Discs		SFN Super Fine	VFN Very Fine	FIN Fine	MED Medium	CRS Coarse	XCRS Extra Coarse	XXCRS X-Extra Coarse
MULTIPURPOSE	PSG Precision		320-280	280-220	220-150	150-120	120-100	
	SC	600-400	400-320		220-180	150-120		
HEAVY DUTY	PSG Precision Heavy Duty				150+	120+	80+	60+
	SE			220-180	180-120	100-80		

## P GRADES

1. Scotch-Brite™ nonwoven abrasives, grade is generally used to describe the finish attributes — the coarser the grade, the more aggressive cut and finish. P Grade ranges for Scotch-Brite™ Discs are based on comparative finishes to 3M paper discs (tested on mild steel and rotary tool). Grade ranges are reference point only — listed from finer to coarser. Measured finish will be affected by operator, tool, accessories used, substrate and application, and provided ranges are reference point only.

# FINISHING GUIDE BY SUBSTRATE

SUBSTRATE ROUGHNESS AVERAGE (RA)						
SCOTCH-BRITE™ SURFACE CONDITIONING DISCS	MINERAL	GRADE	1018 MILD STEEL µIN (MICRON)	304 STAINLESS STEEL µIN (MICRON)	6061 ALUMINUM µIN (MICRON)	
<b>MULTIPURPOSE</b> <b>Precision</b>  	 PSG 3M Precision-Shaped Grain	VFN	11–15 (0.2–0.4)	9–11 (0.2–0.3)	23–38 (0.5–1.0)	
		FIN	16–23 (0.4–0.6)	14–17 (0.3–0.5)	34–53 (0.8–1.4)	
		MED	21–37 (0.5–1.0)	19–23 (0.4–0.6)	65–75 (1.6–2.0)	
		CRS	40–51 (1.0–1.3)	21–27 (0.5–0.7)	69–84 (1.7–2.2)	
		XCRS	42–53 (1.2–1.9)	36–54 (0.9–1.4)	121–140 (3.0–3.6)	
	<b>SC</b> 	 A/O+SiC Aluminum oxide/Silicon carbide	SFN	N/A	5–7 (0.1–0.2)	16–22 (0.4–0.6)
			VFN	10–14 (0.2–0.4)	8–9 (0.2–0.3)	20–25 (0.5–0.7)
			MED	12–17 (0.3–0.5)	19–23 (0.4–0.6)	34–45 (0.8–1.2)
			CRS	17–29 (0.4–0.8)	25–31 (0.6–0.8)	62–84 (1.5–2.2)
			<b>HEAVY DUTY</b> <b>Precision Heavy Duty</b>  	 PSG 3M Precision-Shaped Grain	MED 150+	16–23 (0.4–0.6)
CRS 120+	27–38 (0.6–1.0)	19–28 (0.4–0.8)			75–82 (1.9–2.1)	
XCRS 80+	48–60 (1.2–1.6)	26–38 (0.6–1.0)			121–137 (3.0–3.5)	
XXCRS 60+	68–79 (1.7–2.1)	33–55 (0.8–1.4)			152–177 (3.8–4.5)	
<b>SE</b> 	 A/O Aluminum oxide	FIN		10–24 (0.2–0.7)	16–21 (0.4–0.6)	37–52 (0.9–1.4)
		MED		21–28 (0.5–0.8)	19–24 (0.4–0.7)	64–97 (1.6–2.5)
		CRS		46–57 (1.1–1.5)	36–43 (0.9–1.1)	72–113 (1.8–2.9)

The information we are furnishing is based on tests performed at 3M laboratory facilities. While we believe that these test results are reliable, their accuracy or completeness is not guaranteed. Your results may vary due to differences in test types and conditions. This information is intended for use by persons with the knowledge and technical skills to analyze, handle and use such information. You must evaluate and determine whether the product is suitable for your intended application. The foregoing information is provided "AS-IS". In providing this information 3M makes no warranties regarding product use or performance, including any implied warranty of merchantability or fitness for a particular use.

# SCOTCH-BRITE™ SURFACE CONDITIONING DISCS

General Purpose/Low Pressure Application



## Scotch-Brite™ Precision Surface Conditioning Discs

VFN FIN MED CRS XCRS

PSG + Nonwoven

Features 3M Precision-Shaped Grain for fast cut and long life

Expanded grades cover a large range of applications

Balance of conformability and durability

Bright, vivid colors help to identify easier

**TECH TIP:** You can remove a final sanding step — increasing your productivity!



Roloc™



TN Quick Change



7/8 Center Hole



Hook and Loop



FIND YOUR GRADE AND SIZE

3M™ ROLOC™ SYSTEM

## Build Your System

### UNIVERSAL BACKUP PAD EXAMPLE

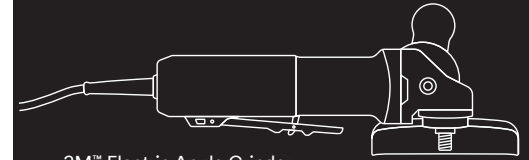

3M™ Electric Angle Grinder  
PN 11129

Scotch-Brite™ Universal Backup Pad PN 89871

Adapter Nut  
M14 / M10 / 5/8–11 Thread

Center Post (Optional)

Scotch-Brite™ Precision Surface Conditioning Disc  
UPC 638060-89244-2

## Check out this additional content!



Precision Disc Portfolio



LEARN MORE



3M™ Disc Pad Face Plate Ribbed



LEARN MORE

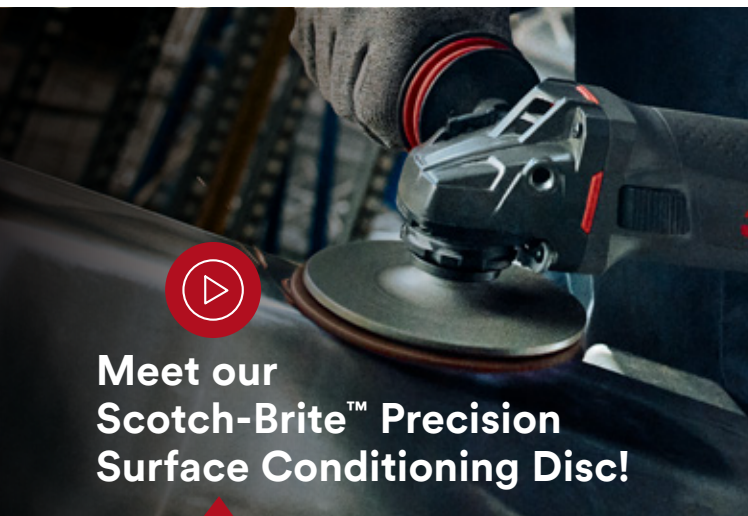

Meet our Scotch-Brite™ Precision Surface Conditioning Disc!

Featuring the Scotch-Brite™ Universal Surface Conditioning Back-up Pad — Designed to optimize the performance of nonwoven abrasive discs. It comes packaged with everything you need for quick and easy tool attachment, including three attachment nuts and an optional snap-in center post. Low-profile design fits within most grinder guards.



LEARN MORE



WATCH VIDEO (1:20 MIN)

# SCOTCH-BRITE™ SURFACE CONDITIONING DISCS

Heavy Duty/High Pressure Application



## Scotch-Brite™ Precision Heavy Duty Surface Conditioning Discs

MED 150+ | CRS 120+ | XCRS 80+ | XXCRS 60+

PSG + Nonwoven

Features 3M Precision-Shaped Grain for fast cut and long life

Expanded grades and variety of sizes to suit your application and substrate

Tough enough for heavy duty use

Edge durability and shape retention during edge wear

Heavy duty family identified by the black backing and white font



Roloc™



TN Quick Change



7/8 Center Hole



Hook and Loop



FIND YOUR GRADE AND SIZE

3M™ ROLOC™ SYSTEM

## Build Your System

### UNIVERSAL BACKUP PAD EXAMPLE

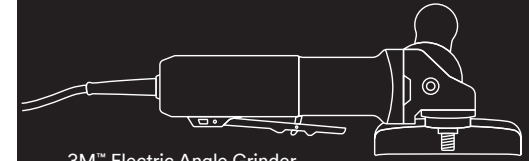

3M™ Electric Angle Grinder  
PN 11129

Scotch-Brite™ Universal  
Backup Pad PN 89871

Adapter Nut  
M14 / M10 / 5/8-11 Thread

Center Post (Optional)

Scotch-Brite™ Precision  
Heavy Duty Surface  
Conditioning Disc  
UPC 068060-67214-8

### 3M™ ROLOC™ EXAMPLE

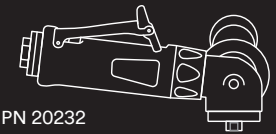

PN 20232

Sander Adapter  
PN 06582

3M™ Roloc™ Disc Pad  
PN 45091

Scotch-Brite™ Roloc™  
Precision Heavy Duty  
Surface Conditioning Disc  
UPC 068060-67198-1

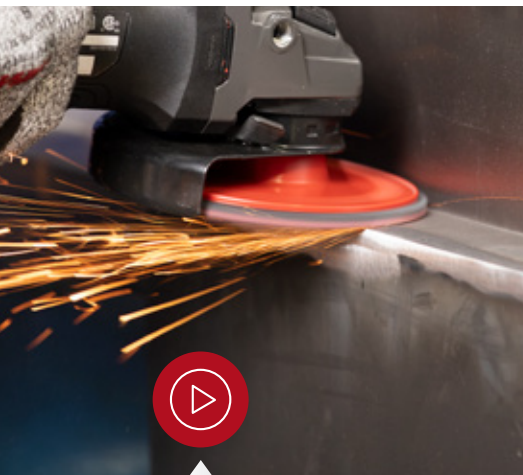

WATCH DEMO VIDEO (0:41 MIN)

## TECH TIP

### Process optimization

Make paint prep on mild steel simple with a 2-step process by combining the fast cutting 3M™ Cubitron™ 3 Fibre Disc and long lasting, fine finishing Scotch-Brite™ Precision Heavy Duty Surface Conditioning Disc.

*For best results use with red (extra hard) or black (hard) 3M™ Disc Face Plates.*



Precision HD  
Disc Portfolio



3M™ Disc Pad  
Face Plate Ribbed



LEARN MORE

# SCOTCH-BRITE™ SURFACE CONDITIONING DISCS

## General Purpose/Low Pressure Application



### Scotch-Brite™ SC Surface Conditioning Discs

SFN VFN MED CRS

Multipurpose for cleaning, blending, light deburring and finishing

Conforms well on irregular / contoured surfaces without undercutting or damaging base material

Aluminum oxide / silicon carbide for super fine

Open-web resists loading

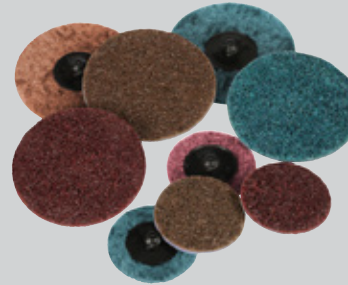

Roloc™



TN Quick Change



7/8 Center Hole



Hook and Loop



3M™ ROLOC™ SYSTEM

FIND YOUR GRADE AND SIZE



## TECH TIP | NEED TO REDUCE VIBRATION?

A "Direct Mount" Disc Pad attachment has a lower profile and offers better control. Check out a Collet accessory for a longer reach.

## Build Your System

### 3M™ ROLOC™ EXAMPLE

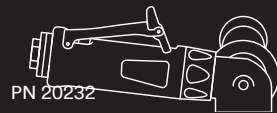

PN 20232

Sander Adapter  
PN 06582



3M™ Roloc™ Disc Pad  
PN 45091



Scotch-Brite™ Roloc™ SC  
Surface Conditioning Disc  
UPC 048011-05532-9



### HOOK AND LOOP EXAMPLE

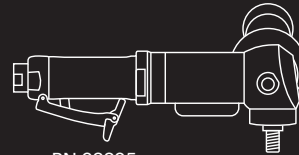

PN 28825

3M™ Hook and Loop  
Disc Pad Holder  
PN 9145



Scotch-Brite™ SC Surface  
Conditioning Disc  
UPC 048011-27672-4



### TN QUICK CHANGE EXAMPLE

2-piece Attachment System

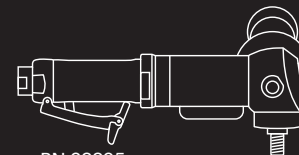

PN 28825

3M™ Disc Pad Hub  
PN 45205



3M™ Disc Pad Face Plate  
PN 14270



Scotch-Brite™ SC Surface  
Conditioning Disc  
UPC 048011-18002-1



### 7/8" CENTER HOLE EXAMPLE

3-piece Attachment System

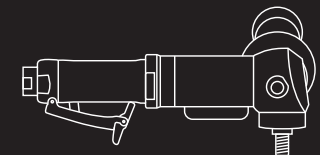

PN 28825

3M™ Disc Pad Hub  
PN 45205



3M™ Disc Pad Face Plate  
PN 14270



Scotch-Brite™ SC Surface  
Conditioning Disc  
UPC 048011-00644-4



3M™ Disc Retainer Nut  
PN 51047



# SCOTCH-BRITE™ CLEAN AND STRIP XT PRO DISCS

## CHOOSE YOUR CUT.

### XT PRO

Rust, paint, light mill scale removal

Maintains workpiece shape

Low sparking

Ideal for surface prep

Made with silicon carbide mineral



### XT PRO EXTRA CUT

Heavy rust / rust pit removal without leaving divots

Thick paint and coating removal

Weld refinement and removing weld discoloration

Cuts to bare metal quickly

Ideal for adhesion prep

Made with aluminum oxide mineral

### BOTH

Rapid coating removal and surface prep

Decreased chunking — extended life

Highly conformable

High speed rating

Quick change, spin-on thread

## CONFORMABILITY TEST

### BETTER CONTACT FOR FASTER REMOVAL

Scotch-Brite™ Clean and Strip XT Pro and XT Pro Extra Cut consistently demonstrate higher conformability.

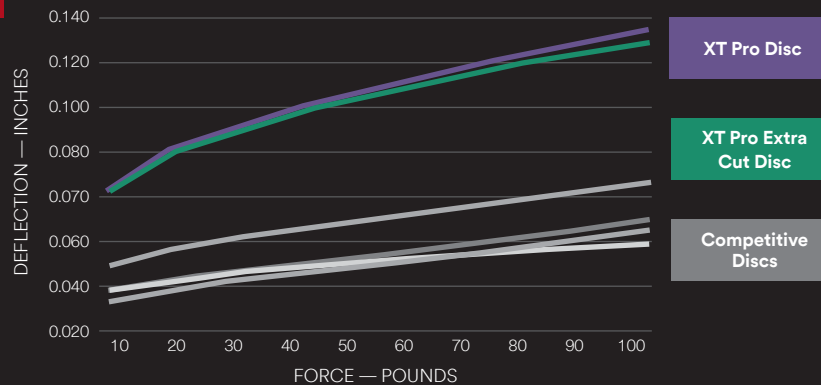

## SPEED WITHOUT COMPROMISE.

Scotch-Brite™ Clean and Strip XT Pro and XT Pro Extra Cut Discs offer increased conformability without undercutting strength. Rated for high speeds, they spin easily onto your angle grinder with a quick-change threaded hub — no accessories needed.

## Check out this additional content!

### Watch our FACT or FICTION Videos!

- [▶ VS. WIRE BRUSH \(1:11 MIN\)](#)
- [▶ RUST PIT REMOVAL \(1:11 MIN\)](#)
- [▶ SEAM SEALER REMOVAL \(1:14 MIN\)](#)
- [▶ DELICATE METAL \(1:12 MIN\)](#)
- [▶ VS. FLAP DISC \(1:15 MIN\)](#)

### Watch a product training video!

- [▶ TRAINING \(15:39 MIN\)](#)

## WATCH VIDEOS

# SCOTCH-BRITE™ CLEAN AND STRIP DISCS



## Scotch-Brite™ Clean and Strip XT Pro Discs

Quickly removes rust, paint, mill scale, coatings from metal and leaves a fine finish

Silicon carbide mineral cuts aggressively

Low sparking

Maintains workpiece shape



Roloc™



TN Quick Change



Center Hole



5/8-11



FIND YOUR GRADE AND SIZE

3M™ ROLOC™ SYSTEM



## Scotch-Brite™ Clean and Strip XT Pro Extra Cut Discs

Heavy rust / rust pit removal without leaving divots, ideal for weld refinement and removing weld discoloration

Aluminum oxide mineral cuts to bare metal quickly

Decreased chunking — extended life



Roloc™



TN Quick Change



Center Hole



5/8-11



FIND YOUR GRADE AND SIZE

3M™ ROLOC™ SYSTEM

## Build Your System

### 3M™ ROLOC™ + SYSTEM EXAMPLE

PN 20240



3M™ Roloc™+ Holder  
PN 07500



Scotch-Brite™ Roloc™+ Clean  
and Strip XT Pro Disc  
UPC 638060-21542-5



### 7/8" CENTER HOLE EXAMPLE

1-piece Attachment System

PN 28825

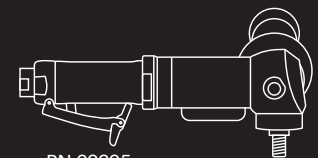

3M™ Adapter Nut 5/8-11 Thread  
PN 88765



Scotch-Brite™ Clean and Strip  
XT Pro Disc Type 27  
UPC 638060-05586-1



3M™ Adapter Nut 5/8-11 Thread  
PN 88765



# SCOTCH-BRITE™ UNITIZED WHEELS

## HIGH PERFORMANCE AND DURABILITY.

Scotch-Brite™ Unitized Wheels are stacked, compressed layers of nonwoven web designed to bring abrasive to the part. Performance differences between unitized wheels can be attributed to mineral (aggressiveness) and density (hardness). The combination of these two characteristics and subtle variations determine if the wheel will cut more aggressively or will be more durable and less conformable.

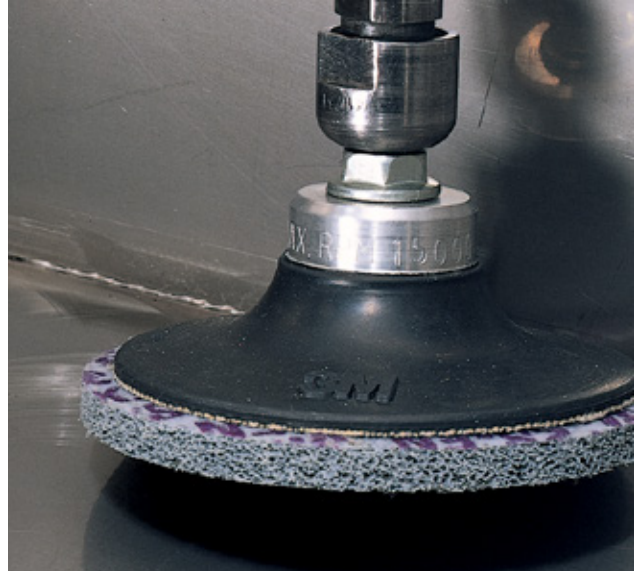
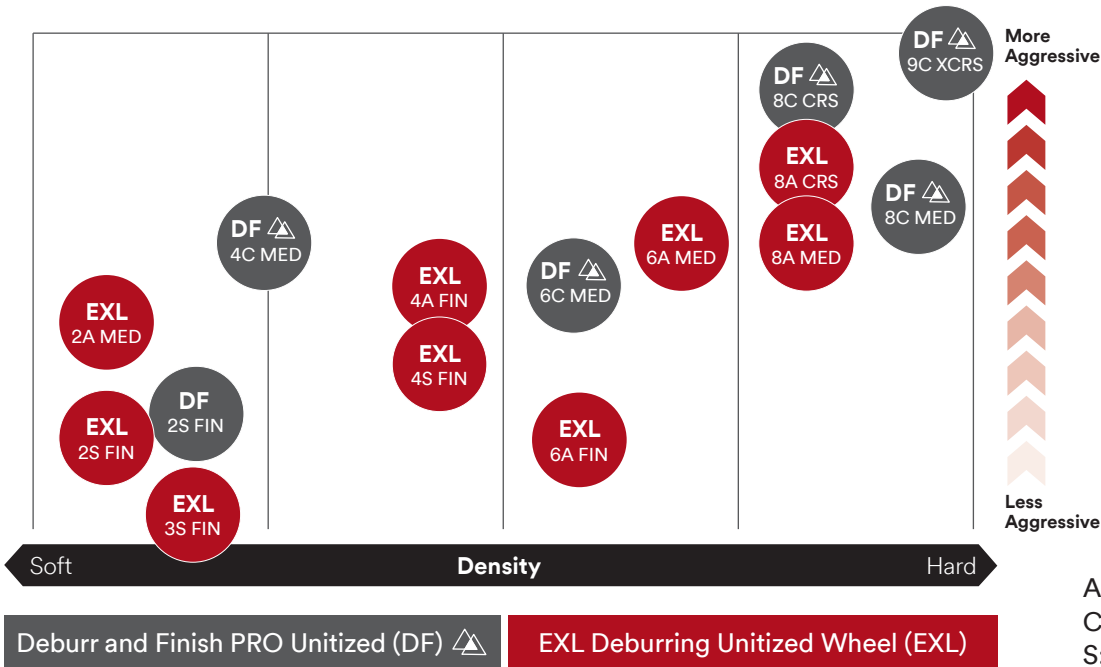

## COOL UNDER PRESSURE.

Scotch-Brite™ Unitized Wheels are manufactured with compressed, nonwoven fiber construction and uniform grain distribution. These rugged, fast cutting wheels produce great results on all types of metal, composites and glass.

Smaller wheels are designed for use on die grinders and angle grinders.

### TECHNOLOGY

## 3M PRECISION-SHAPED GRAIN NONWOVEN TECHNOLOGY

Scotch-Brite™ Deburr and Finish PRO Unitized Wheels combine 3M Precision-Shaped Grain with our nonwoven technology, so you get a wheel that's soft enough to reduce defects but wears like iron without sacrificing the smooth feel and control you expect from Scotch-Brite™ Wheels.

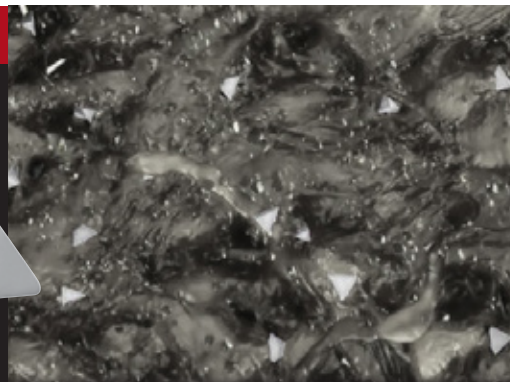

Check out this additional content!



WATCH VIDEO (1:42 MIN)

# SCOTCH-BRITE™ UNITIZED WHEELS



## Scotch-Brite™ Deburr and Finish PRO Unitized Wheels

3M Precision-Shaped Grain is engineered to cut fast and sharp, enabling quicker burr removal

Quickly polish, finish, blend and deburr

Nonwoven construction minimizes loading and change to part geometry

Up to 3X longer wheel life in deburring applications



T27



Center Hole



Roloc™



FIND YOUR GRADE AND SIZE

3M™ ROLOC™ SYSTEM



## Scotch-Brite™ EXL Unitized Deburring Wheels

For deburring, finishing and polishing of all metal alloys and plastics and composites

Densities and grades ranging from soft and conformable to hard and aggressive offer utility for a wide variety of applications

Resists smearing and minimizes heat buildup on the work piece

Conformable to complex-shaped parts



Center Hole



Roloc™



FIND YOUR GRADE AND SIZE

3M™ ROLOC™ SYSTEM

## Build Your System

### 3M™ COLLET SYSTEM EXAMPLE

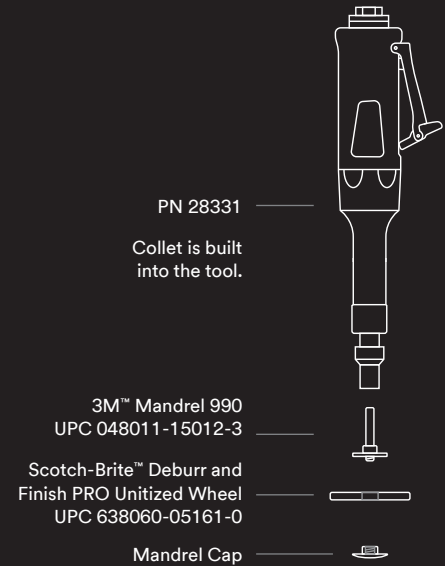

### 3M™ ROLOC™ EXAMPLE

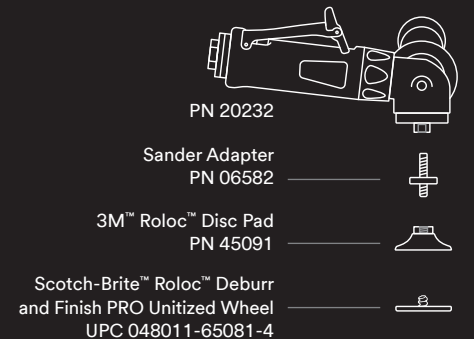

## TECH TIP | COLLETS

Different collet sizes are available for a variety of shaft / spindle / mandrel diameters.

# SCOTCH-BRITE™ UNITIZED WHEELS



## Scotch-Brite™ Cut and Polish Unitized Wheels

Highly durable and aggressive to remove oxides, rusts and colors to produce a shiny or polished finish

Aluminum oxide mineral has high cut-rate, hardness and strength

Excellent for aggressive heavy duty blending and finishing with uniform results

Good replacement for rubber bonded wheels and small set-up wheels



**FIND YOUR GRADE AND SIZE**



Center Hole



Roloc™



**3M™ ROLOC™ SYSTEM**



## Scotch-Brite™ Laser Braze Finishing Wheel

**PSG**

Built with 3M Precision-Shaped Grain for long life and fewer wheel changes

Used for smoother more refined brazed surfaces that don't require as much removal/leveling

Very strong and flexible, for advanced force control



**FIND YOUR GRADE AND SIZE**



Center Hole

## Scotch-Brite™ Unitized Wheels Classification

### FAMILY



### DENSITY



### MINERAL

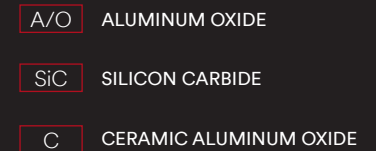

### GRADE

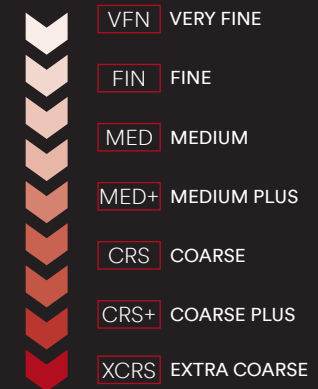

APPLICATIONS	Deburring	Blending	Finishing	Polishing
Deburr and Finish PRO	✓	✓	✓	
EXL	✓	✓	✓	✓
Cut and Polish		✓	✓	✓
Laser Braze	✓	✓	✓	

# SCOTCH-BRITE™ CONVOLUTE WHEELS

## REACH YOUR DEBURRING AND FINISHING POTENTIAL.

Get high performance and durability, Scotch-Brite™ Convolute Wheels produce great results on all types of metal, composites and glass. Used on pedestal grinders, back stands and bench motors, these wheels provide a consistent working surface even as the wheel wears.

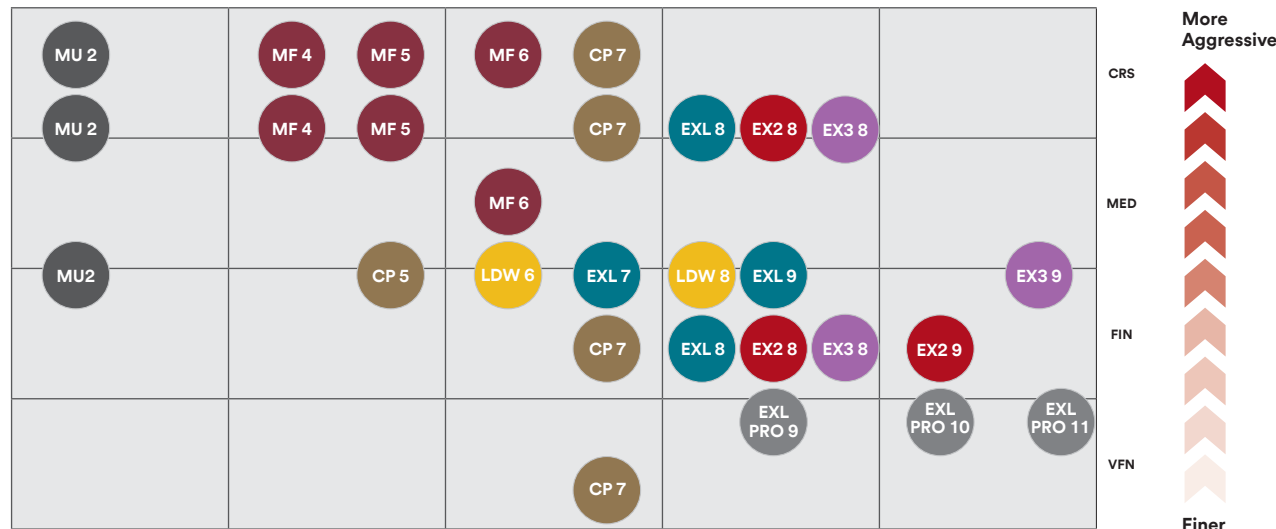

Soft Density Hard

SCOTCH-BRITE™ CONVOLUTE WHEEL	Deburring	Blending	Finishing	Polishing
EXL / EX2 / EX3 Deburring (EXL)	✓	✓		
EXL Pro Deburring (EXL PRO)	✓			
Metal Finishing (MF)		✓	✓	
Cut and Polish (CP)		✓	✓	✓
Multi-Finishing (MU)		✓	✓	
Light Deburring (LDW)			✓	✓

RECOMMENDED OPERATING SPEEDS	
Application	SFPM
Finishing	500 – 3,000
Composites / Soft Materials	1,200 – 2,700
Deburring	5,000 – 7,500
Blending / Polishing	6,000 – 8,000

SFPM = Surface Feet Per Minute

MAXIMUM OPERATING SPEEDS	
Diameter	RPM
4"	9,000
6"	6,000
8"	4,500
10"	3,600
12"	3,000
14"	2,550
16"	2,250
18"	2,000
20"	1,800
24"	1,500



## FOR WHEN YOU NEED TO ACHIEVE A FINE FINISH.

Engineered to strike a balance between durability and conformability to deliver unmatched results in deburring, weld blending, finishing and polishing applications.

Scotch-Brite™ Wheels are powered by nonwoven technology — a conformable nylon web with incorporated abrasive grain developed by 3M engineers.





# SCOTCH-BRITE™ CONVOLUTE WHEELS — FINISHING



## Scotch-Brite™ Cut and Polish Wheels

For aggressive finishing applications, and is good for defect removal and scratch blending

Produces a dull finish with a tight scratch pattern

Most durable of our finishing wheels



Density	Mineral	Grade	Dia.	Width
5, 7	A/O	VFN, FIN, MED, CRS	4"–24"	.5"–36"



**FIND YOUR GRADE AND SIZE**



## Scotch-Brite™ Light Deburring Wheels

Provides a clean and effective system for removing fine burrs while providing a highly polished finish

Produces a bright and consistent finish with tight scratch pattern

Very soft and conformable



Density	Mineral	Grade	Dia.	Width
6, 7, 8	SiC	FIN	4"–24"	.5"–36"



**FIND YOUR GRADE AND SIZE**

## CONVOLUTE WHEELS VS. UNITIZED WHEELS

Often determined by the part configuration, wheel size availability, and tool speed.

### CONVOLUTE

typically bigger wheels and used on stationary equipment

### UNITIZED

typically smaller wheels and used on portable tools

## 3M PRESENTS THE “FINISHING FOUR.”

The easiest way to achieve the look you’re going for!



### METAL FINISHING WHEELS

create a satin finish that is somewhat coarser and duller than our light deburring wheels.

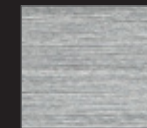

### MULTI-FINISHING WHEELS

create a bright finish with a wide scratch pattern.

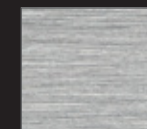

### CUT AND POLISH WHEELS

produce a dull finish with a tight scratch pattern.



### LIGHT DEBURRING WHEELS

produce a bright and consistent finish with a tight scratch pattern.

# SCOTCH-BRITE™ FLATSTOCK AND HAND PADS

## FIND YOUR HAND PAD.

Use the selection guide below to find the right mineral, grit coarseness and finish for your application — including light duty cleaning, blending and finishing and every surface prep task in between.

START HERE

**Durable Flex**  
Most Flexible Option

Flexible, durable gray hand pad. Long lasting, tear and load resistant for fast, consistent action without compromising finish.

**7447**  
Trusted General Purpose Hand Pad

Most popular general purpose hand pad. Dark maroon pad cleans, blends, finishes and deburrs.

**Durable Flex**  
Long Lasting — Specially Coated to Resist Loading

Flexible, durable maroon hand pad. Long lasting, tear and load resistant for fast, consistent action without compromising finish.

**7447 Pro**  
Most Durable and Aggressive

Long lasting maroon hand pad for uniform scratch. Specialty coated to resist loading.

FULL PORTFOLIO

Less Aggressive / Finer Finish

More Aggressive / Coarser Finish



7445	7448	Durable Flex	7448 Pro	7447	Durable Flex	7447 Pro	8447	7446	7440
F SFN	S ULF	S ULF	S ULF	A VFN	A VFN	A VFN	A VFN	S MED	A MED

F = Nepheline Syenite    S = Silicon Carbide    A = Aluminum Oxide  
SFN = Super Fine    ULF = Ultra Fine    VFN = Very Fine    MED = Medium

## DELIVERING PRECISE HAND CONTROL.

Scotch-Brite™ Hand Pads give you a fast, consistent scuff for everyday surface preparation. Ideal for cleaning parts and scuffing prior to staining and painting. Similar performance to steel wool without the rusting or splintering.

Check out this additional content!



WATCH VIDEO (2:30 MIN)

## TECH TIP

**Aluminum Oxide (A):** A more durable mineral that performs in aggressive applications.  
**Silicon Carbide (S):** A sharper mineral and is used for finer finishing applications.

# SCOTCH-BRITE™ HAND PADS AND FLATSTOCK

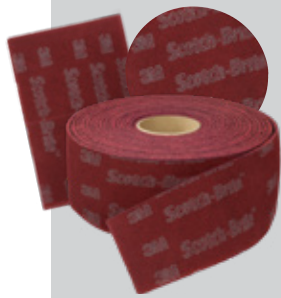

## Scotch-Brite™ Hand Pads 7447 Pro

Very fine grade aluminum oxide mineral cleans and finishes efficiently

Tightly graded abrasive particles for consistent, uniform scratch throughout life of the hand pad

Long lasting pad made with durable nonwoven nylon web is flexible enough to get into hard-to-sand places; Specially coated to minimize loading

Cleans, finishes and scuffs a wide variety of surfaces, offering supreme versatility

Can be used wet or dry and rinsed for repeated use



**FIND YOUR GRADE AND SIZE**

**MORE FORMS AVAILABLE**



## Scotch-Brite™ Hand Pads 7448 Pro

Ultra fine finishing action outperforms steel wool for cleaning, blending, prepping and finishing on metal, wood, plastics and composites

Cuts faster and produces a more consistent finish than conventional nonwoven abrasive products

Long lasting pad is specially coated to minimize loading

Pad conforms to irregular surfaces and gets into corners without losing performance

Performs like steel wool grade 00 without shredding, rusting, or splintering



**FIND YOUR GRADE AND SIZE**

**ROLLS AVAILABLE**

## Build Your System

### RANDOM ORBITAL SANDER EXAMPLE

3M™ Hookit™ System

PN 28708

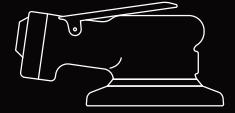

3M™ Hookit™ Low Profile Disc Pad  
PN 28852



Scotch-Brite™ Hookit™  
7447 Pro Disc  
UPC 048011-65071-5

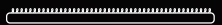

**PERFORATED  
HAND PADS ARE  
EASY TO USE!**

# SCOTCH-BRITE™ HAND PADS AND FLATSTOCK



## Scotch-Brite™ Hand Pads 7447

Superior alternative to steel wool, wire brushes, and sandpaper

Use on wood, metal, plastics, ceramics, porcelain, rubber, or composites

Very fine grade aluminum oxide abrasive cleans, finishes, grains, denibs, defuzzes



**TECH TIP:** If you want 7447 in a roll / sheet / disc, try Scotch-Brite™ Clean and Finish Abrasive A VFN



FIND YOUR GRADE AND SIZE



## Scotch-Brite™ Hand Pads 7448

High performance pads are packed with tightly graded abrasive mineral for more consistent, fast cut

Flexible pad cleans, blends and finishes where conformability is needed

Ideal for prepping surfaces for primer and color coat, general scuffing and cleaning



**TECH TIP:** If you want 7448 in a roll / sheet / disc, try Scotch-Brite™ Clean and Finish Abrasive S ULF

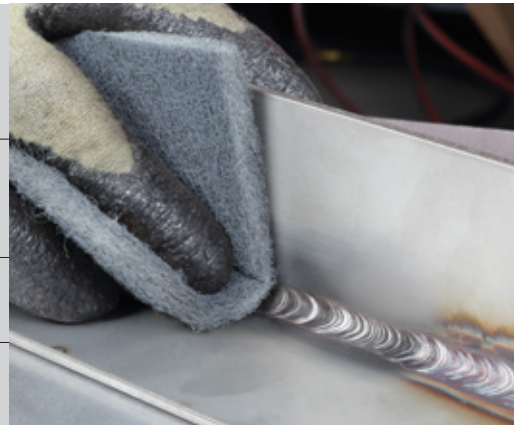

FIND YOUR GRADE AND SIZE



# SCOTCH-BRITE™ HAND PADS AND FLATSTOCK



## Scotch-Brite™ Durable Flex Hand Pads

Flexible pad cleans, blends and finishes where conformability is needed

Tightly graded abrasive mineral provides consistent, fast cut

Ideal for prepping surfaces for primer and color coat, general scuffing, cleaning and hand blending

Silicon Carbide Ultra Fine (S ULF) performs like steel wool grade 00; Aluminum Oxide Very Fine (A VFN) performs like steel wool grade 1



**TECH TIP:** Don't want a standard hand pad? Try a roll and tear off your perfect size!



FIND YOUR GRADE AND SIZE

ROLLS AVAILABLE



## Scotch-Brite™ Heavy Duty Hand Pad 7440

Aggressive, durable pad for heavy cleaning, deburring and finishing

Very high density, super aggressive for quick stock removal

Withstands extremely heavy use on tough surfaces

Cuts fast to remove coatings and corrosion in demanding cleaning and finishing applications









**TECH TIP:** If you want 7440 in a roll / sheet / disc, try Scotch-Brite™ Cut and Polish Abrasive

FIND YOUR GRADE AND SIZE













# SCOTCH-BRITE™ SURFACE CONDITIONING BELTS

TRUST SCOTCH-BRITE™ BELTS TO DELIVER FANTASTIC FINISHES.

RECOMMENDED BACKINGS							
		File Belt	In-Line Sander	Stroke Sander	Back Stand	Centerless / Cylindrical	Flat Finishing
Scotch-Brite™ SC Surface Conditioning Belt	SCRIM	✓	✓				
	LOW STRETCH*				✓	✓	✓
	FILM BACKED			✓			
Scotch-Brite™ Durable Flex (DF) Surface Conditioning Belt	LOW STRETCH*	✓	✓		✓	✓	✓
	SCRIM	✓	✓				
Scotch-Brite™ SE Surface Conditioning Belt	LOW STRETCH*				✓	✓	✓
	FILM BACKED			✓			
	SCRIM						

\*Low stretch is ideal for high tension or long belt applications

FLEXIBLE Resistant to chunking	MULTIPURPOSE The original multipurpose surface conditioning belt	HEAVY DUTY Holds up to sharp edges and burrs
		
		
		
		

More Aggressive



RECOMMENDED OPERATING SPEEDS	
Application	SFPM
Decorative Finishing	500 – 3,000
Deburring	5,000 – 6,500
Cleaning and Conditioning	2,000 – 5,000
Oxide Removal	4,500 – 6,500

Maximum Operating Speed: 6,500 SFPM  
SFPM = Surface Feet Per Minute

## THE EASIEST WAY TO A PERFECT FINISH.

Choose Scotch-Brite™ Surface Conditioning Belts for cleaning, finishing, blending and deburring. The reinforced backing offers good flexibility whether working on a file belt or backstand. The nonwoven material combined with abrasive grain is an ideal way to add a great finish or remove burrs without gouging or undercutting the work piece.



# CRACKING THE COLOR CODE — BELTS

HAVE CONFIDENCE THAT YOU ARE USING THE REAL DEAL.

Recognizing the authentic Scotch-Brite™ Brand colors can help you to quickly identify quality nonwoven abrasives — and their grades.<sup>1</sup>

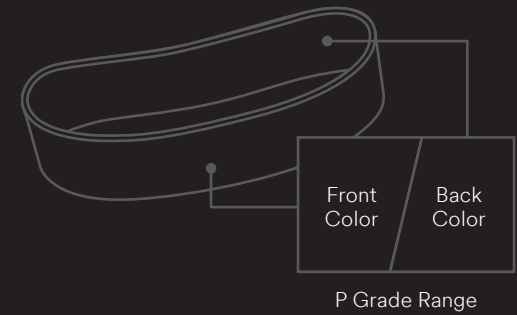

Scotch-Brite™ Surface Conditioning Belts		SFN Super Fine	VFN Very Fine	FIN Fine	MED Medium	CRS Coarse
MULTIPURPOSE	SC	 600–400	 400–320		 240–180	 180–150
FLEXIBLE	Durable Flex (DF)			 280–240	 240–180	 180–150
HEAVY DUTY	SE			 280–240	 240–180	 150–120

## P GRADES

1. Scotch-Brite™ nonwoven abrasives, grade is generally used to describe the finish attributes — the coarser the grade, the more aggressive cut and finish. P Grade ranges for Scotch-Brite™ Belts are based on comparative finishes to 3M coated belts (tested on stainless steel). Grade ranges are reference point only — listed from finer to coarser. Measured finish will be affected by operator, tool, accessories used, substrate and application, and provided ranges are reference point only.

# SCOTCH-BRITE™ SURFACE CONDITIONING BELTS



## Scotch-Brite™ SC Surface Conditioning Belts

Premium Scotch-Brite™ surface conditioning nonwoven web

Designed for cleaning, finishing and light deburring

SCRIM

For use on portable, benchtop and backstand equipment

Backing: Scrim, Low Stretch, Film Backed



**FIND YOUR GRADE AND SIZE**



FILM BACKED

LOW STRETCH



**ADDITIONAL BACKING OPTIONS**



## Scotch-Brite™ Durable Flex (DF) Surface Conditioning Belt

Durable flex belt has great edge durability

Aggressive and long lasting belt for deburring, finishing, blending and cleaning

LOW STRETCH

The reinforced low stretch backing offers good flexibility

Ideal for file belts applications

Backing: Low Stretch



**FIND YOUR GRADE AND SIZE**



**TIP:** It's easy to identify DF Belts by the Scotch-Brite™ branded purple backing!

## Build Your System

### 3M™ INLINE SANDER EXAMPLE

PN 28339

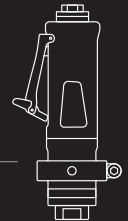

3M™ Wheel Adapter Kit  
PN 45038



3M™ Rubber Slotted  
Expander Wheel  
5" x 3-1/2", 5/8 Arbor Hole  
PN 28348

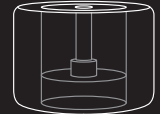

Adapter Kit Cap



Scotch-Brite™ SC Surface  
Conditioning Belt  
3-1/2" x 15-1/2"  
UPC 048011-05228-1



### 3M™ FILE BELT EXAMPLE

PN 28366



3M™ File Belt Sander  
Attachment Arm  
PN 28368



Scotch-Brite™  
Durable Flex Belt  
UPC 048011-64455-4



## TECH TIP

Is your belt wearing out too fast?  
Try the Scotch-Brite™ SE Surface Conditioning Belt.

# SCOTCH-BRITE™ SURFACE CONDITIONING BELTS



## Scotch-Brite™ SE Surface Conditioning Belts

Coarse grade aluminum oxide, tough, aggressive nonwoven belt for heavy duty deburring and finishing



SCRIM



For use on backstand and off hand equipment

Identifiable by light blue backing

Backing: Scrim, Low Stretch, Film Backed

LOW STRETCH



FIND YOUR GRADE AND SIZE

ADDITIONAL BACKING OPTION

## SCOTCH-BRITE™ SURFACE CONDITIONING BELTS PERFORMANCE COMPARISON

Resistant to Dulling and Loading



SC

DURABILITY



DF



SE

Resistant to Wear and Sharp Edges

Least



SE

FLEXIBILITY



SC



DF

Most

Scotch-Brite™ SC Surface Conditioning Belts (SC)

Scotch-Brite™ Durable Flex Surface Conditioning Belts (DF)

Scotch-Brite™ SE Surface Conditioning Belts (SE)

## Scotch-Brite™ SE Surface Conditioning Belts

### RECOMMENDED EQUIPMENT



Back Stand



Centerless / Cylindrical



# SCOTCH-BRITE™ FLAP BRUSHES

SELECT THE FLAP BRUSH FOR YOUR APPLICATION.

- 1 FINISHING**  
 Ultra light duty cleaning and finishing operations.
- 2 CUT AND POLISH**  
 Cleaning and finishing applications that require a more aggressive brush or a brighter finish.
- 3 PREMIUM BLEND AND FINISH**  
 Aggressive finishing and medium cleaning / deburring applications.
- 4 HIGH STRENGTH**  
 Medium duty cleaning and finishing requiring a brush with longer life and more durability.

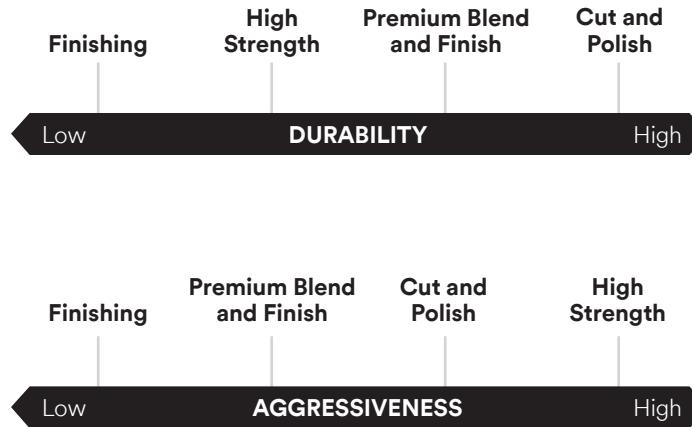

RECOMMENDED OPERATING SPEEDS	
Application	SFPM
Decorative Finishing*	500 – 3,000
Composites / Soft Materials	1,200 – 2,700
Cleaning and Conditioning	2,000 – 5,000
Prepolishing	2,000 – 7,000
Oxide Removal	4,500 – 6,500
Deburring	5,000 – 6,500
Wood Sanding	500 – 2,500

SFPM = Surface Feet Per Minute

\*Finishing Flap Brushes should not be run over 3,500 SFPM

FLAP BRUSHES	
Core	Spindle Mount, 5/8–11 Quick Change, Fiberglass (varies on diameter)
Size	3/4" – 48"
Tool / Machine	Match and Finish Sander, Backstand, Die Grinder, Bench Motor



## CLEAN, DEBURR OR FINISH.

Scotch-Brite™ Brushes offer versatility for cleaning, finishing and deburring metal, plastics, wood and more. Available in a wide range of grades and brush constructions to help you tailor brush performance to your specific application — do it all, faster and more consistently.

### TECH TIP

Increase density to improve life and durability. Most common industrial grinding lubricants, coolants, and/or compounds can be used with Scotch-Brite™ Brushes.

# SCOTCH-BRITE™ FLAP BRUSHES



## Scotch-Brite™ Finishing Flap Brush

Soft density and medium / fine / very fine abrasive grades produce brushed surfaces without compounds

Provides more surface contact than bristle-type brushes

Continuously supplies fresh abrasives for consistent, uniform finishes

Nonwoven web is load and heat resistant, enabling fine finishing results



**FIND YOUR GRADE AND SIZE**

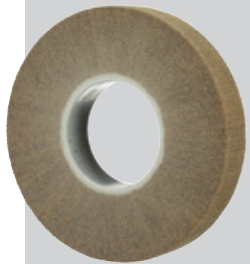

## Scotch-Brite™ Cut and Polish Flap Brush

Great for medium / heavy duty cleaning, deburring, polishing and finishing

Open web is load resistant, enabling aggressive cleaning and bright finishing

Deburs stamped or laser-cut parts

Conforms well on irregular / contoured surfaces without undercutting or damaging base material



**FIND YOUR GRADE AND SIZE**

## Build Your System

### MATCH AND FINISH SANDER EXAMPLE

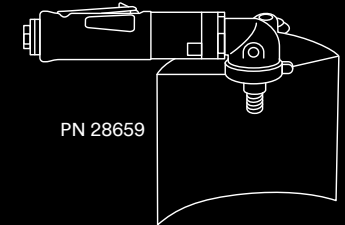

PN 23659

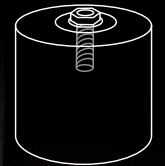

Scotch-Brite™  
Match and Finish Flap Brush  
4-1/2" x 4" x 5/8-11  
UPC 051141-55745-8



# SCOTCH-BRITE™ SURFACE CONDITIONING MOLDED ABRASIVES

## SCOTCH-BRITE™ BRISTLE BRUSHES AND DISCS Safer operation and conformability in contoured areas



### Long life with consistent performance

Scotch-Brite™ Bristle Discs and Brushes last longer than most abrasives and provide the same finish and cut throughout their life. For productivity in automated procedures, there are fewer changeovers.



### Conformability and more surface contact

Unlike most abrasives, Scotch-Brite™ Bristle products are flexible and conform to irregular surfaces. They require less manipulation by operators on parts. You can expect a consistent finish even on the most complex parts.



### Safety

To help you meet increasingly tough safety standards, Scotch-Brite™ Bristle Discs contain no wire filaments. When replacing chemicals or compounds, they have the added benefit of not emitting harmful chemical vapors.

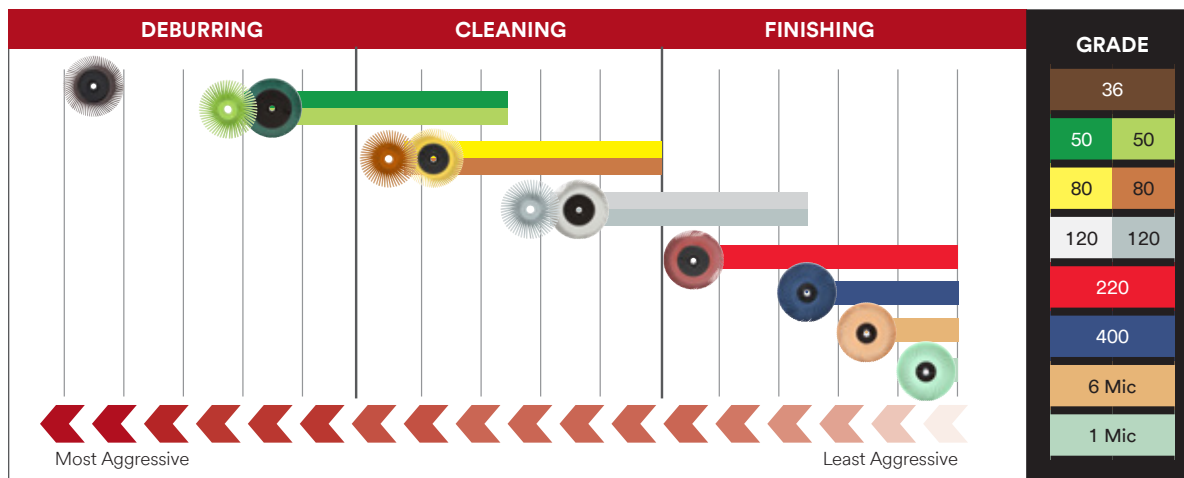

## MORE EFFECTIVE THAN WIRE BRUSHES

Scotch-Brite™ Precision Bristle products contain 3M Precision-Shaped Grain technology designed for consistent cut and finish, and load resistant.

# SCOTCH-BRITE™ BRISTLE DISCS AND BRUSHES

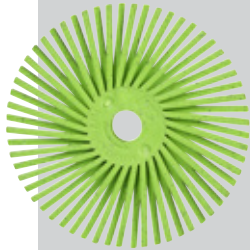

## Scotch-Brite™ Precision Radial Bristle Brushes

50 80 120



Built with 3M Precision-Shaped Grain for increased cut-rate without sacrificing finish

Flexible bristles produce uniform finishes around protrusions, detail grooves, patterns, and other hard-to-reach areas

Conformability allows abrasive to stay in contact with complex-shaped parts in robotic processing

Contains no wire filaments to help enhance user safety

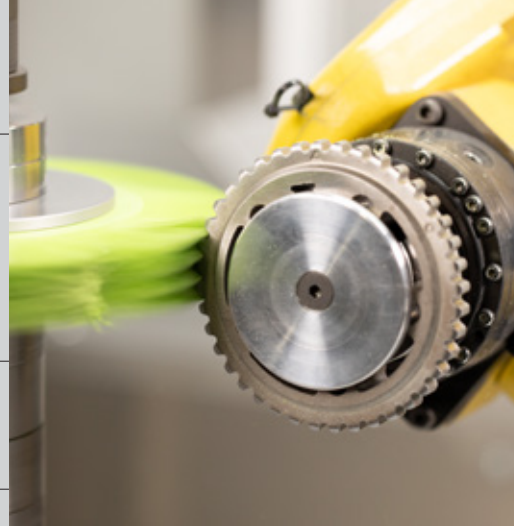

FIND YOUR GRADE AND SIZE

## UPGRADED FOR HIGH PERFORMANCE

This brush is extremely adaptable, conformable, and cleans with minimal pressure — making it ideal for manual and robotic processes.



WATCH VIDEO  
(2:37 MIN)

## Build Your System



**STRAIGHT — TYPE S (TS)**  
Rigid and very aggressive for cleaning and deburring, non-directional.



**ANGLED — TYPE A (TA)**  
Rigid and very aggressive, similar to Type S but for smaller diameters, directional.

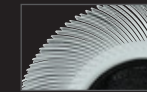

**CURVED — TYPE C (TC)**  
Less aggressive and more conformable, directional.

### 3M™ COLLET SYSTEM EXAMPLE

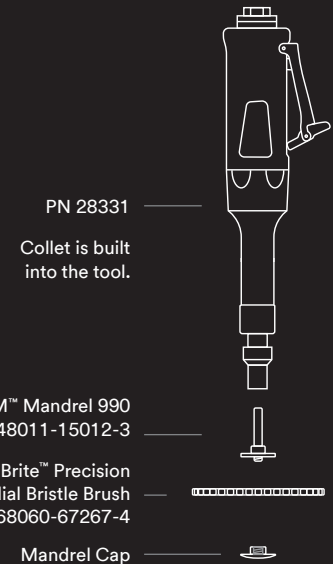

# SCOTCH-BRITE™ BRISTLE DISCS AND BRUSHES

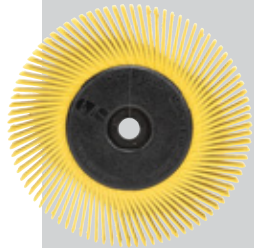

## Scotch-Brite™ Radial Bristle Brushes

Ideal for Robotic Deburring to quickly remove burrs and sharp edges in end-of-arm tooling operations

Conformability allows abrasive to stay in contact with complex-shaped parts in robotic processing

Maintains abrasive property throughout the life of the brush



**FIND YOUR GRADE AND SIZE**

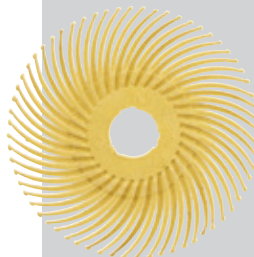

## Scotch-Brite™ Radial Bristle Discs

Fast running disc removes paint, stains, adhesives, weld burns and heavy oxides from large areas

Conform to the part and clean without removing base material reducing damage and rework

Create an incredibly uniform finish even around protrusions, detail grooves, patterns and other hard to reach areas



**FIND YOUR GRADE AND SIZE**



Roloc™



**3M™ ROLOC™ SYSTEM**

## Build Your System



**STRAIGHT — TYPE S (TS)**  
Rigid and very aggressive for cleaning and deburring, non-directional.



**ANGLED — TYPE A (TA)**  
Rigid and very aggressive, similar to Type S but for smaller diameters, directional.



**CURVED — TYPE C (TC)**  
Less aggressive and more conformable, directional.

### 3M™ MANDRELS EXAMPLE

3M™ Mandrel 990  
UPC 048011-15012-3



Scotch-Brite™ Radial Bristle Brush  
UPC 048011-27605-2



Mandrel Cap



### 3M™ ROLOC™ SYSTEM EXAMPLE



PN 20232

3M™ Sander Adapter  
PN 06582



3M™ Roloc™ Disc Pad  
PN 45091



Scotch-Brite™ Roloc™ Radial Bristle Disc  
UPC 048011-24276-7



# SCOTCH-BRITE™ BRISTLE DISCS AND REMOVAL WHEELS



## Scotch-Brite™ Bristle Discs

Bristle spacing is ideal for removing paint, stains, adhesives, weld burn, rust and other high-loading substances

Proprietary 3M™ Ceramic Abrasive Grain provides aggressive cut and consistent finish throughout the life of the disc

Flexible bristles require less pressure than wire brushes and conform to contours



RoLoc™



FIND YOUR GRADE AND SIZE

3M™ ROLOC™ SYSTEM



## Scotch-Brite™ Stripe Off Wheels and Molded Adhesive Removal Discs

Effectively removes unwanted vinyl decals, graphics and striping tapes from metal and painted surfaces

Polyvinyl Chloride (PVC) is durable and stands up to repeated friction for effective removal of unwanted decals

Disc generates heat as it spins, minimizing the need for prep work with heat tools



FIND YOUR GRADE AND SIZE

## Build Your System

### 3M™ ROLOC™ SYSTEM EXAMPLE

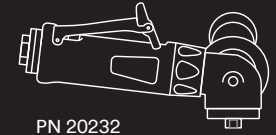

PN 20232

3M™ Sander Adapter  
PN 06582



3M™ Roloc™ Disc Pad  
PN 45091



Scotch-Brite™ Roloc™  
Bristle Disc  
UPC 048011-24276-7



# SCOTCH-BRITE™ NONWOVEN ABRASIVES TRIAL PACKS

Trial Packs help make it easier than ever for your customers to experience the power, performance and convenience of Scotch-Brite™ Nonwoven Abrasives.

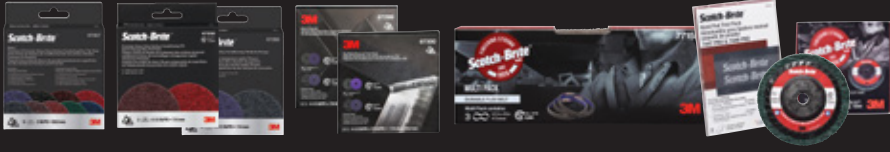

SINGLE PACKS	PRODUCT	CONTENTS	SIZE / GRADE	UPC
	Scotch-Brite™ Precision Surface Conditioning Disc TN Quick Change (QC)	1 Disc	4-1/2" Coarse	638060-89343-2
		1 Disc	4-1/2" Medium	638060-89344-9
	Scotch-Brite™ Roloc™+ Clean and Strip XT Pro Extra Cut Disc, TR+	1 Disc	4" x 1/2" A Extra Coarse	638060-29917-3
	Scotch-Brite™ Roloc™+ Clean and Strip XT Pro Disc, TR+	1 Disc	4" x 1/2" S Extra Coarse	638060-29911-1
	Scotch-Brite™ Clean and Strip XT Pro Extra Cut Disc, Type 27 QC	1 Disc	4-1/2" x 5/8-11" A Extra Coarse	638060-29901-2
Scotch-Brite™ Clean and Strip XT Pro Disc, Type 27 QC	1 Disc	4-1/2" x 5/8-11" S Extra Coarse	638060-29900-5	
MULTI PACKS	Scotch-Brite™ Precision Heavy Duty Surface Conditioning TN Quick Change Discs	2 Discs (1 Each Grade)	4-1/2" x NH MED 150+, CRS 120+	068060-67259-9
		2 Discs (1 Each Grade)	4-1/2" x NH XCERS 80+, XXCRS 60+	068060-67260-5
	Scotch-Brite™ Durable Flex Surface Conditioning Belts	3 Belts	1/2" x 18" A CRS	076308-77158-4
		3 Belts	1/2" x 18" A MED	076308-77157-7
		3 Belts	1/2" x 18" A FIN	076308-77154-6
	3M™ Hand Pads 7447 Pro / 7448 Pro	2 Hand Pads (1 Each Grade)	6" x 9" Very Fine, Ultra Fine	048011-64933-7
Scotch-Brite™ Roloc™ Unitized Wheel Pack 988S	6 Wheels (1 Each Grade)	3" 2A MED, 2S FIN, 6A MED, 6S FIN, 8A MED, 8A CRS	048011-17182-1	

PRODUCT	CONTENTS	SIZE / GRADE	UPC
3M™ Roloc™ Disc, TR	9 Discs (1 Each Grade)	3" / XCERS, CRS, MED, FIN, VFN, XXCRS 60+, XCRS 80+, CRS 120+, Med 150+	068060-67258-2
	9 Discs (1 Each Grade)	2" / XCERS, CRS, MED, FIN, VFN, XXCRS 60+, XCRS 80+, CRS 120+, Med 150+	068060-67257-5
3M™ Roloc™ Disc, TR 9815S*	6 Discs (2 Each Grade)	1-1/2" A VFN, A MED, A CRS	051144-82901-9
	4 Discs (2 Each Grade)	1-1/2" SD A CRS, HD A CRS	
	9 Discs (2 Each Grade)	1-1/2" 36+, 60+, 80+	
3M™ Roloc™ Disc, TR 982S*	6 Discs (2 Each Grade)	2" A VFN, A MED, A CRS	051144-82899-9
	4 Discs (2 Each Grade)	2" SD A CRS, HD A CRS	
	6 Discs (3 Each Grade)	2" 36+, 60+, 80+	
3M™ Roloc™ Disc, TR 983S*	6 Discs (2 Each Grade)	3" A VFN, A MED, A CRS	051144-82900-2
	4 Discs (2 Each Grade)	3" SD A CRS, HD A CRS	
	9 Discs (3 Each Grade)	3" 36+, 60+, 80+	
3M™ Roloc™ Disc, TR 984S*	6 Discs (2 Each Grade)	4" A VFN, A MED, A CRS	051141-28039-4
	4 Discs (2 Each Grade)	4" SD A CRS, HD A CRS	
	9 Discs (3 Each Grade)	4" 36+, 60+, 80+	
3M™ Roloc™ Disc, TR 985S**	12 Discs (2 Each Grade and Size)	2" and 3" A VFN, A MED, A CRS	048011-18254-4
	8 Discs (2 Each Grade and Size)	2" and 3" SD A CRS, HD A CRS	
3M™ Paint Prep Kit	1 Disc	4-1/2" x 7/8" XXCRS 60+	068060-67299-5
	1 Disc	4-1/2" x 7/8" 36+	
3M™ Tig Weld Removal	1 Disc	4-1/2" x 7/8" XXCRS 60+	068060-67300-8
	1 Disc	4-1/2" x 7/8" 60+	

\*Also includes 1 each 3M™ Roloc™ Disc Pad TR (Hard); 3M™ Roloc™ Shank. \*\*Also includes 1 each 3M™ Roloc™ Disc Pad 2" and 3"; 3M™ Roloc™ Shank.

# TOOLS AND ACCESSORIES

Complete your line up. Scotch-Brite™ Nonwoven Abrasives deliver with the full system — tools, accessories and safety. Increasing your productivity one job at a time.



FOR MORE INFORMATION  
DOWNLOAD CATALOG:  
**3M™ Power Tools and Accessories**

## DISC SANDERS

Pages 48 ▶



## ELECTRIC GRINDER

Pages 48 ▶



## DIE GRINDERS

Page 48 ▶



## RANDOM ORBITAL SANDER

Pages 49 ▶



## INLINE FINISH SANDER

Page 49 ▶



## MATCH AND FINISH SANDER

Page 49 ▶



## FILE BELT SANDER

Page 49 ▶



## ACCESSORIES

Page 50 ▶



# 3M™ POWER TOOLS

Choosing the right Scotch-Brite™ Nonwoven Abrasives for your surface finishing project is critical — and so is using the right tool. Whether your job calls for an angle grinder or sanding tool, 3M has you covered with the power tools, accessories and service you need.

## 3M™ DISC SANDER RIGHT ANGLE SYSTEM

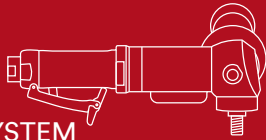

A lightweight, compact design with a high power-to-weight ratio to help you get more work done in less time

Great for grinding, blending, weld leveling, metal prep and other metal fabrication applications



[LEARN MORE](#)

## 3M™ DISC SANDER 3M™ ROLOC™ SYSTEM



Weighs less than 1.5 lbs. for versatility and ease of use in tight spaces

Designed specifically for light duty finishing jobs and intermittent spot repair; great for paint stripping and weld cleanup



[LEARN MORE](#)

## 3M™ ELECTRIC ANGLE GRINDER

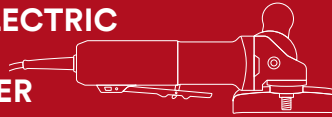

High torque and high rotational speed in a lightweight, powerful tool designed for operator comfort

Versatile for grinding, cutting, beveling, blending, cleaning and finishing



[LEARN MORE](#)

## 3M™ DIE GRINDER RADIAL MOUNTED SYSTEM



Straight shaft die grinder designed to grind in hard to reach areas; collet insert available

Great for heavy stock removal and weld leveling as well as removing rust / debris from internal diameters of small cylinders



[LEARN MORE](#)

# 3M™ POWER TOOLS

Choosing the right Scotch-Brite™ Nonwoven Abrasives for your surface finishing project is critical — and so is using the right tool. Whether your job calls for an angle grinder or sanding tool, 3M has you covered with the power tools, accessories and service you need.

## 3M™ RANDOM ORBITAL SANDER



Dual action produces a swirl-free finish, even when sanding against the grain



[LEARN MORE](#)

## 3M™ INLINE FINISH SANDER

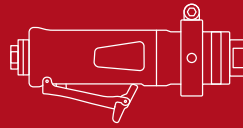

Straight shaft sander is easy to control and simplifies finish matching

Generate directional finishes and prepare metals for final finishing, finish to spec, or grind and blend of welds



[LEARN MORE](#)

## 3M™ MATCH AND FINISH SANDER

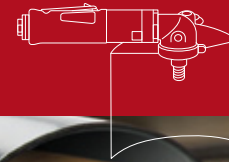

Generate straight-line scratches for finishing stainless steel and other metals



[LEARN MORE](#)

## 3M™ FILE BELT SANDER



A lightweight hand-held sander enabling the operator to maneuver and manipulate the abrasive belt, turning and rotating up to 360 degrees to blend hard-to-reach areas



[LEARN MORE](#)

# 3M™ ACCESSORIES

Listed below are the accessories highlighted throughout this catalog. CLICK or TAP the icons to link to the product details.

For full list of available accessories and other sizes, please refer to the 3M Tools and Accessories catalog on page 47.

## Scotch-Brite™ Universal Surface Conditioning Back-up Pad

PN 89869 – 4"  
PN 89870 – 4.5"  
PN 89871 – 5"



## 3M™ Disc Pad Face Plate Ribbed

PN 88655 – 4.5"  
PN 88656 – 5"  
PN 88657 – 7"



## 3M™ Disc Pad Face Plate



## 3M™ Disc Pad Hub PN 45205



## 3M™ Roloc™ Disc Pad



## 3M™ Sander Adapter PN 06582



## 3M™ Hook and Loop Disc Pad Holder



## 3M™ Hookit™ Low Profile Disc Pad PN 20352



## 3M™ Roloc™+ Holder PN 07500



## 3M™ File Belt Sander Attachment Arm

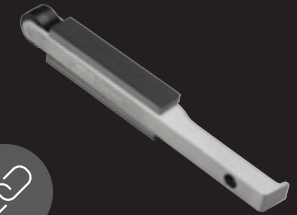

## 3M™ Rubber Slotted Expander Wheel 5" x 3-1/2" 5/8" Arbor Hole



## 3M™ Wheel Adapter Kit PN 45038



## 3M™ Mandrel 990 UPC 048011-15012-3



## 3M™ Disc Retainer Nut



## 3M™ Adapter Nut 5/8–11 Thread PN 88765



# SAFETY

3M provides safety solutions that work as hard as you do. From the most basic to the most specialized needs, 3M offers the most effective protection available, so everyone can perform at their best.



LEARN MORE AT:  
[3M.com/PPESafety](https://3M.com/PPESafety)

Not a complete list. Please choose the right products for each application and exposure assessment.

## 3M OFFERS PERSONAL PROTECTIVE EQUIPMENT (PPE) TO HELP KEEP WORKERS SAFE.



### 3M™ Reusable Respirators

3M provides a full line of reusable respirators to meet the needs of any work environment. Half or full facepiece reusable respirators help protect against both particles and/or gases and vapors.



### 3M™ Aura™ Particulate Respirators 9300+ Series

Ergonomic, flat-fold, 3-panel design. Valved and unvalved models available. Respirators feature an innovative chin tab for easy adjustments and an embossed, sculpted upper panel to help reduce eyewear fogging.



### 3M™ Ratchet Headgear H8A, with 3M™ Clear Polycarbonate Faceshield

Provides optical clarity and high-performance durability in unpredictable environments that involve exposure to impact hazards and flying debris.



### 3M™ SecureFit™ Protective Eyewear

Soft adjustable nose pads and dual injected temples help diffuse pressure over the ear to enhance frame comfort while not compromising the security of fit.



### 3M™ E-A-R™ UltraFit™ Earplugs

Reusable and designed for insertion into the ear canal to help reduce exposure to harmful levels of noise. Each set of plugs is supplied with a pre-tipped cord, meaning you can insert and have corded or remove and have uncorded, giving you the option to wear as you choose.

### WARNING

These eye and face protection products help provide limited eye and face protection. Misuse or failure to follow warnings and User Instructions may result in serious potential injury, including blindness or death. For proper use, selection and applications against flying particles, optical radiation and / or splash, see supervisor, read User Instructions and warnings on the package, or call 3M PSD Technical Service in the USA at 800-243-4630. In Canada, call Technical Service at 800-267-4114.



# ABRASIVE SOLUTIONS BY 3M. EVER FORWARD.

A finish you can feel.



A finish you can see.



A finish unmatched.



## WARRANTY / DISCLAIMER

**Product Use:** Many factors beyond 3M's control and uniquely within user's knowledge and control can affect the use and performance of a 3M product in a particular application. Given the variety of factors that can affect the use and performance of a 3M product, user is solely responsible for determining whether it is fit for a particular purpose and suitable for user's method of application.

**Warranty, Limited Remedy, and Disclaimer:** 3M warrants this tool against defects in workmanship and materials under normal operating conditions for one (1) year from the date of purchase. 3M MAKES NO OTHER WARRANTIES, EXPRESS OR IMPLIED, INCLUDING, BUT NOT LIMITED TO, ANY IMPLIED WARRANTY OF MERCHANTABILITY OR FITNESS FOR A PARTICULAR PURPOSE OR ANY IMPLIED WARRANTY ARISING OUT OF A COURSE OF DEALING, CUSTOM OR USAGE OF TRADE. User is responsible for determining whether the 3M tool is fit for a particular purpose and suitable for user's application. User must operate the tool in accordance with all applicable operating instructions, safety precautions, and other procedures stated in the operating manual to be entitled to warranty coverage. 3M shall have no obligation to repair or replace any tool or part that fails due to normal wear, inadequate or improper maintenance, inadequate cleaning, non-lubrication, improper operating environment, improper utilities, operator error or misuse, alteration or modification, mishandling, lack of reasonable care, or due to any accidental cause. If a tool or any part thereof is defective within this warranty period, your exclusive remedy and 3M's sole obligation will be, at 3M's option, to repair or replace the tool or refund the purchase price.

**Limitation of Liability:** Except where prohibited by law, 3M will not be liable for any loss or damage arising from the 3M product, whether direct, indirect, special, incidental or consequential, regardless of the legal theory asserted, including warranty, contract, negligence or strict liability.

3M Abrasive Products are for Industrial Use Only.





SCOTCH-BRITE™ PROVIDES AN EXPERIENCE YOU CAN RECOGNIZE,  
FEEL AND TRUST — CONSISTENTLY DELIVERING THE CUT AND FINISH  
EVERYONE DESERVES TO **GET THE JOB DONE RIGHT.**



LEARN MORE AT:  
[3M.com/ScotchBriteAbrasives](https://3M.com/ScotchBriteAbrasives)

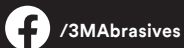

/3MAbrasives



/3MAbrasives



/3MAbrasives

**3M**

3M Abrasive Systems  
3M Center, Building 223-6N-02  
St. Paul, MN 55144 USA

Phone 1-866-279-1235  
Web [3M.com/abrasives](https://3M.com/abrasives)

3M, Aura, Cubitron, E-A-R, Hookit, Roloc, Scotch-Brite and SecureFit are trademarks of 3M.  
Please recycle. Printed in U.S.A. © 3M 2026. All rights reserved. 61-5005-0007-1 Rev-2-26